

ORAC[®]
DECOR

FREE YOUR
PERSONALITY

ORAC[®]
D E C O R

FREE YOUR *PERSONALITY*

en

Show who you are.

Whoever you are, wherever you live, you are you and you want to show it. In your house, in your environment, in the place you call home. Find your own style and put your personality in the spotlight. Whether you prefer a masterful modern or character-filled classic style, this collection of original skirting boards, elegant cornices, stylish panel mouldings and innovative indirect lighting will transform your house into a dream home. A unique place that says who you are and how you approach life. But enough about us: let's talk about you.

ru

Покажите, кто Вы на самом деле.

Кем бы Вы ни были, где бы Вы не жили, Вы - это Вы и Вы хотите это показать. В окружающем мире и в том месте, которое Вы называете домом. Найдите свой собственный стиль и поместите свою индивидуальность в центр внимания. Предпочитаете ли Вы свободный современный или характерный классический стиль, коллекции оригинальных плинтусов, элегантных карнизов, стильных молдингов и инновационных карнизов для скрытого освещения превратят ваш дом в дом мечты, отражающий вашу личность. Уникальное место, которое говорит, кто Вы и как относитесь к жизни. Но достаточно разговоров о нас: давайте поговорим о Вас.

pl

Pokaż kim jesteś.

Kimkolwiek jesteś, gdziekolwiek mieszkasz masz swój charakter, swoją osobowość i chcesz to pokazać zarówno w domu jak i wśród otoczenia, w którym się znajdujesz. Znajdź swój własny styl i wyróżnij swoją osobowość. Niezależnie od tego czy preferujesz nowoczesny czy pełen charakteru klasyczny styl, prezentowana przez nas kolekcja pełna jest eleganckich gzymsów, stylowych i oryginalnych listew zarówno przypodłogowych jak i sufitowych oraz innowacyjnych rozwiązań oświetleniowych, które sprawią, że twój dom zmieni się w pełny charakteru dom twoich marzeń. Spraw, aby stał się on wyjątkowym miejscem, które mówi kim jesteś i jak podchodzisz do życia.

ar

أظهروا من أنتم.

كائنًا من كنتم، أينما كنتم تعيشون، أنتم أنفسكم وتريدون أن تظهروا ذلك. في منزلكم، في البيئة الخاصة بكم، في المكان الذي تعتبرونه بيتكم. جدوا أسلوبكم الخاص واظهروا شخصيتكم. سواء كنتم تفضلون الطراز الحديث المتقن أو الكلاسيكي ذات طابع مميز، فإن هذه المجموعة من النعلات البديعة، الكرائيش الأنيقة، قوالب الجدران المميزة، والإضاءة غير المباشرة المبتكرة، ستحول منزلكم إلى منزل الأحلام المفعم بالشخصية. مكان فريد من نوعه يقول من أنتم وكيف تقاربون الحياة. ولكن كفا كلاما عنا: دعونا نتحدث عنكم.

fr

Montrez qui vous êtes.

Qui que vous soyez. Quel que soit l'endroit où vous habitez. Vous êtes vous et vous voulez le montrer. Dans votre logement, dans votre environnement, dans l'endroit que vous considérez comme votre foyer. Affirmez votre propre style et mettez votre personnalité en avant. Carrément moderne ou typiquement classique : cette collection de plinthes originales, de corniches et de cimaises élégantes et d'éclairage indirect innovant va transformer votre maison en un lieu de rêve éclatant de caractère. Un endroit unique qui révèle votre personnalité et votre manière de voir la vie. Mais assez parlé de nous: qui êtes-vous ?

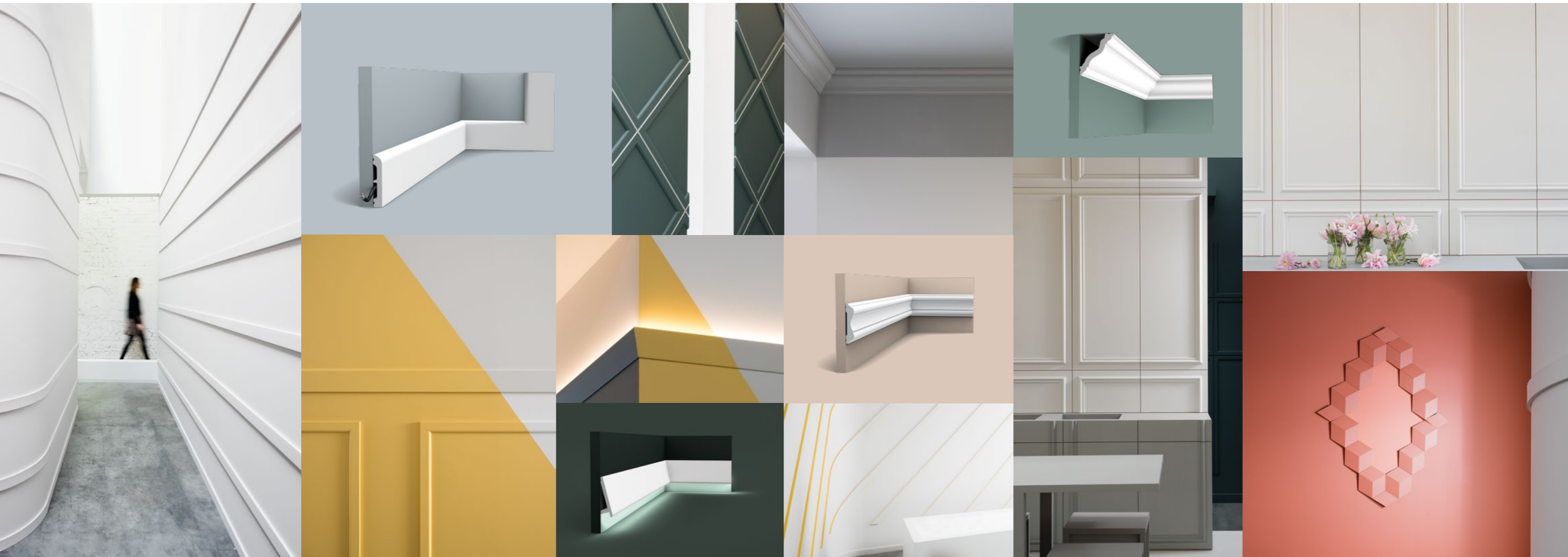

Content

en

06 Your style, your space
08 Hall
18 Living room
32 Kitchen
44 Bathroom
54 Bedroom
62 Projects
80 Materials
82 Product Overview
84 Cornice Mouldings
104 Panel Mouldings
114 Skirting
126 Indirect Lighting
138 Deco Elements
154 The Perfect Finish
156 Flexible Products

ru

06 Ваш стиль, ваше пространство.
08 Зал
18 Гостиная
32 Кухня
44 Ванная комната
54 Спальня
62 Проекты
80 Материалы
82 Ассортимент
84 Карнизы
104 Молдинги
114 Плинтю
126 Скрытое Освещение
138 Декоративные элементы
154 Идеальный финиш
156 Гибкие профили

pl

06 Twój styl, twoja przestrzeń.
08 Hol
18 Pokój dzienny
32 Kuchnia
44 łazienka
54 Sypialnia
62 Projekty
80 Materiały
82 Przegląd Produktów
84 Gzymsy
104 Profile ściienne
114 Listwy przypodłogowe
126 Listwy oświetleniowe
138 Elementy dekoracyjne
154 Idealne Wykończenie
156 Produkty Elastyczne

ar

06 أسلوبكم، مساحتكم.
08 مدخل
18 صالون
32 مطبخ
44 حمام
54 غرفة نوم
62 مشاريع
80 المواد
82 نظرة عامة على المنتجات
84 كرائيش
104 قوالب للجدران
114 نعلات
126 إضاءة غير مباشرة
138 أصناف للزينة
154 مظهر نهائي مثالي
156 المنتجات المرنة

fr

06 Votre style, votre espace.
08 Hall
18 Séjour
32 Cuisine
44 Salle de bains
54 Chambre à coucher
62 Projets
80 Matériaux
82 Aperçu Produits
84 Corniches
104 Cimaises
114 Plinthes
126 Eclairage Indirect
138 Eléments Décoratifs
154 La Finition Parfaite
156 Produits Flexibles

Your style, your space.

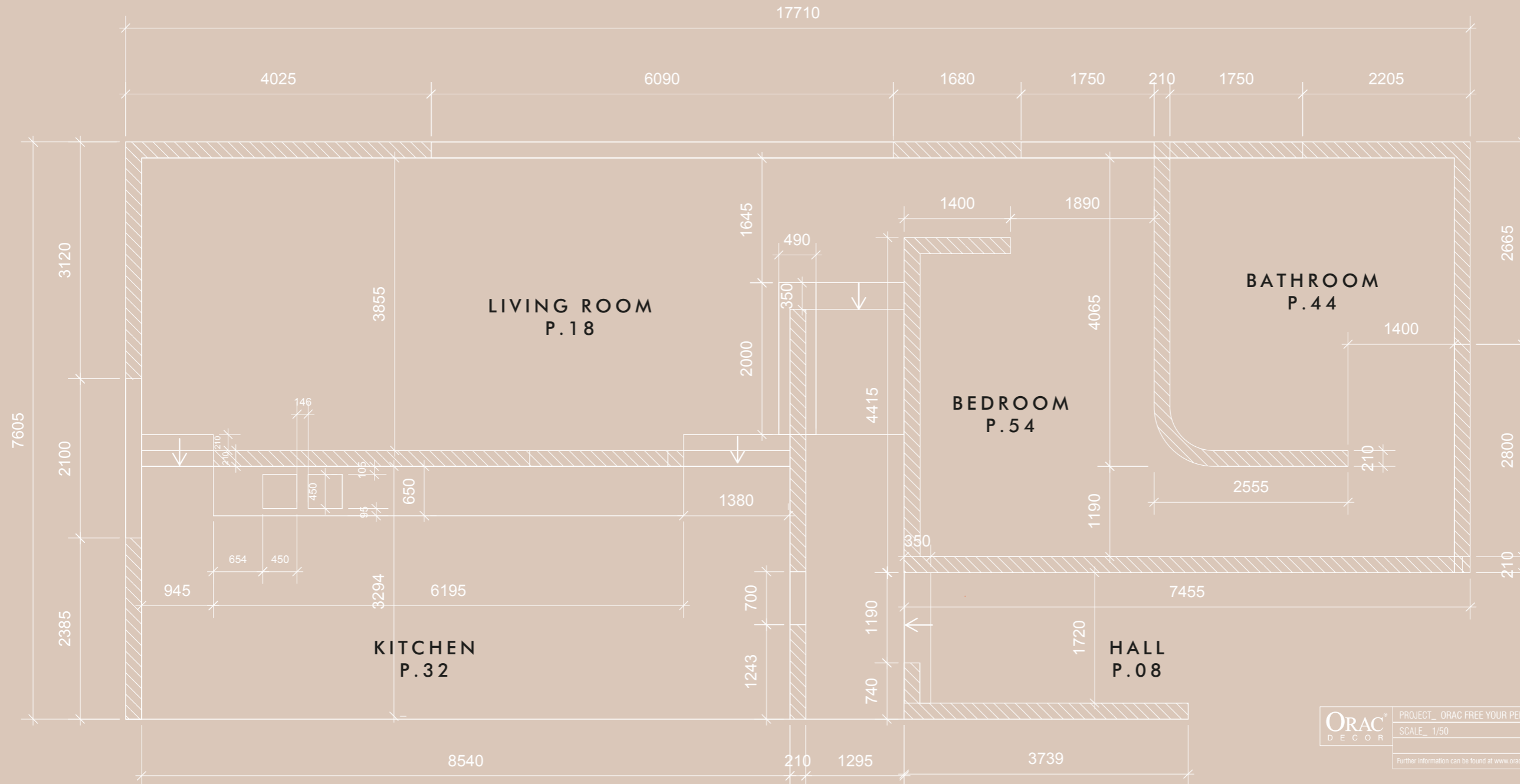

ORAC [®] DECOR	PROJECT_ ORAC FREE YOUR PERSONALITY HOUSE	Birkhofstraat 82 8400 Doornik, België T +32 (0)59 80 32 52 F +32 (0)59 80 28 10 info@oracdecor.com www.oracdecor.com
	SCALE_ 1/50	
Further information can be found at www.oracdecor.com		Version 1.0

en

Your style, your space.

From living room to bedroom, kitchen to bathroom: be inspired by our projects and create your own dream world. The only limit is your own creativity. Welcome to your interior.

ru

Ваш стиль, ваше пространство.

От гостиной и до спальни, от кухни и до ванной комнаты: вдохновляйтесь нашими интерьерами и создавайте ваш собственный волшебный мир. Вас остановит только Ваша креативность. Добро пожаловать в интерьер Вашей мечты!

pl

Twój styl, twoja przestrzeń.

Od salonu po sypialnię, kuchnię i łazienkę inspiruj się naszymi projektami i stwórz swój własny wymarzony świat. Jedynym ograniczeniem jest twoja własna wyobraźnia i kreatywność. Witaj w świecie marzeń.

ar

أسلوبكم، مساحتكم.

من الصالون إلى غرفة النوم، من المطبخ إلى الحمام: استوحوا من مشاريعنا واخلقوا عالم الأحلام الخاص بكم. الحد الوحيد هو إبداعكم الشخصي. أهلاً بكم داخل منزلكم.

fr

Votre style, votre espace.

Du salon à la chambre à coucher, de la cuisine à la salle de bains : laissez-vous inspirer par nos idées et créez votre propre univers de rêve. Votre créativité sera votre seule limite. Bienvenue chez vous.

9:00am *In the*
HALL



A BITE OF
PERSONALITY



Light in the darkness.

Create your own
unique fixtures.



ru

Свет во тьме.
Создайте свои уникальные
устройства.

pl

Światło w ciemności.
Stwórz własne unikalne wystroje
wnętrz.

ar

ضوء في الظلام.
اخلقوا الإضاءة الخاصة بكم .

fr

Lumière dans l'obscurité.
Créez votre espace unique.

HALL

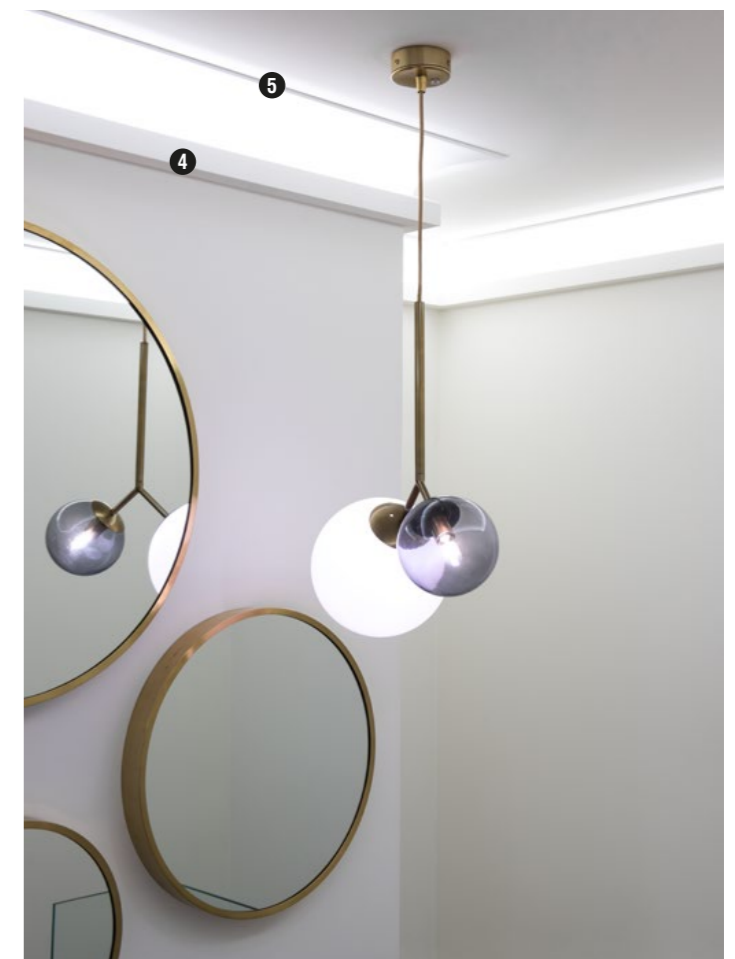

❶ C380 p.131

❷ C383 p.131

❸ SX181 p.120

❹ C380 p.131

❺ C991 p.89

❻ C357 p.128

❼ SX157 p.118

- 1 P8030 p.106
- 2 P4020 p.106
- 3 SX118 p.120
- 4 C339 p.90

HALL





ru

Вдохните жизнь в серые стены.

pl

Przekształć puste ściany w przyciągającą wzrok elewację.

ar

حولوا الجدران العارية إلى مساحات ملفتة للنظر.

fr

Des murs dépouillés accrocheront instantanément le regard.

HALL

- 1 DX121-2300 p.112
- 2 SX155 p.119
- 3 D503 p.151
- 4 SX122 p.118
- 5 P8030 p.106
- 6 C339 p.90



Transform bare walls into eye-catching elevations.

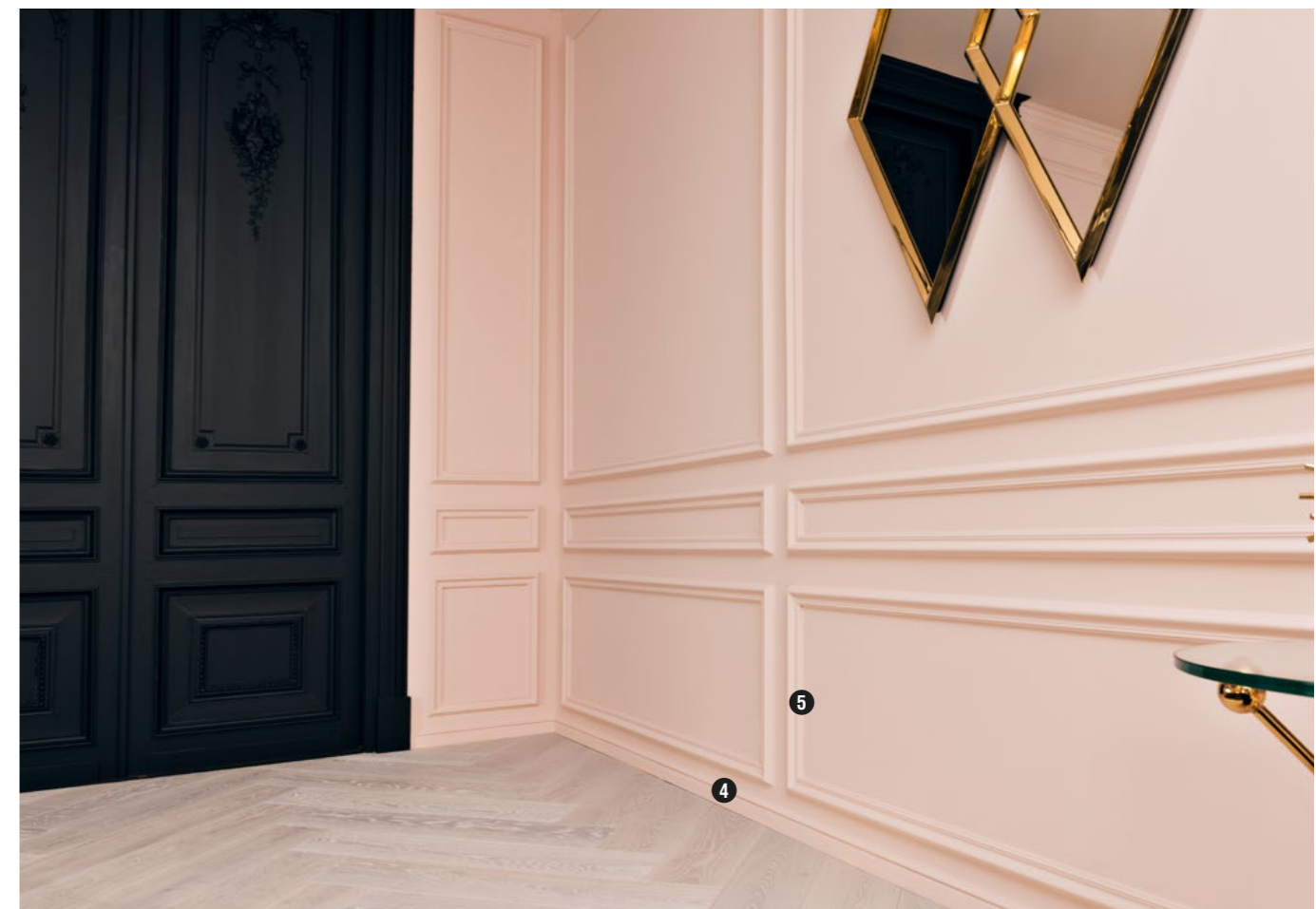

Who said your hall needs to be a dark and boring space?

HALL



1 C381



ru

Кто сказал, что коридор должен быть самым тёмным и скучным местом в доме?

pl

Kto powiedział, że powierzchnie w twoim domu muszą być mrocznymi i nudnymi przestrzeniami?

ar

من قال أن المدخل يجب أن يكون مظلمًا ومملًا؟

fr

Votre hall est un espace sombre et ennuyeux ? Il y a plein de possibilités !

1 C381 p.131

2 SX181 p.120

3 C341 p.88

4 DX121-2300 p.112

5 P8030 p.106

6 SX118 p.120



PERSONALITY
IS YOUR BEST OUTFIT

9:00pm *In the*
LIVING ROOM



LIVING ROOM

- ❶ C380 p.131
- ❷ SX181 p.120
- ❸ C902 p.129
- ❹ P8020 p.106
- ❺ P8050 p.108
- ❻ SX118 p.120



❷ SX181

LIVING ROOM

ru

Выигрышная комбинация.
Установите скрытое освещение
внутри карниза для создания
эффекта дополнительного
пространства.

pl

Łączenia wygrywają.
Dla uzyskania efektu bardziej
przestronnego pomieszczenia
umieść oświetlenie pod listwą.

ar

تركيبة موفقة.
ضعوا الإضاءة غير المباشرة تحت الكورنيش
لتظهر المساحة أكثر اتساعاً.

fr

Combinaison gagnante.
Placez votre éclairage indirect
sous votre corniche pour une
sensation d'espace.

- ❶ C396 p.135
- ❷ C395 p.135
- ❸ SX187 p.118
- ❹ C990 + 2X P9900 p.92
- ❺ C381 p.131
- ❻ SX181 p.120



A winning combination.

Place your indirect lighting under your cornice for a more spacious effect.

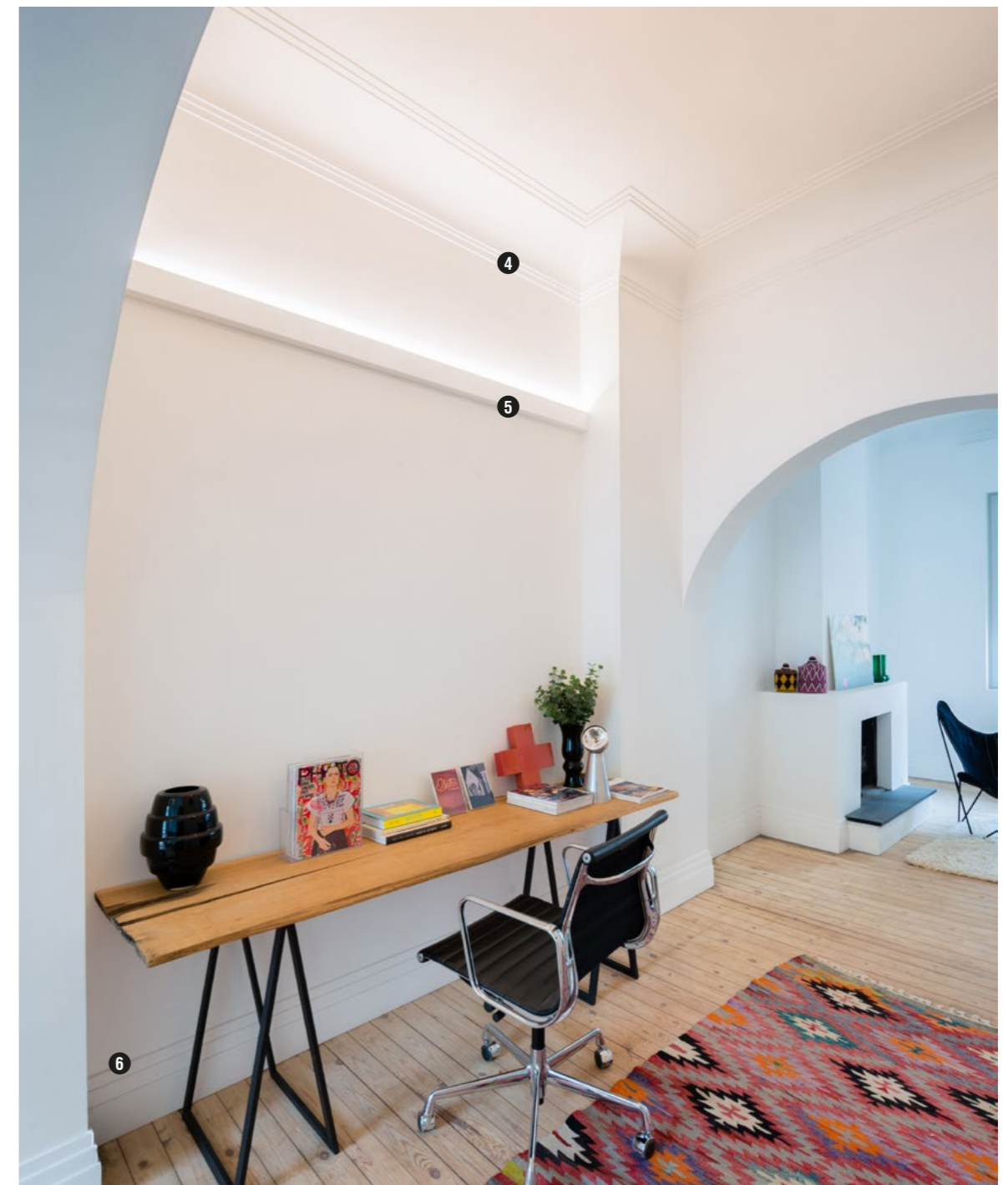



Our panel mouldings will transform your wall into a work of art.

Use
your
wall
as a
blank
canvas.



- 1 P9010 p.107
- 2 P4020 p.106
- 3 P8020 p.106
- 4 SX118 p.120
- 5 PX103 p.110
- 6 SX155 p.119
- 7 C219 p.93

LIVING ROOM



ru
Превратите стену в чистый холст. Наши молдинги превратят стены в произведение искусства.

ar
استعملوا الحائط كلوحة. قوالب الجدران ستحول حائطكم إلى تحفة فنية.

pl
Użyj ściany jako płótna, a nasze listwy przysufitowe zmienią twoje ściany w dzieło sztuki.

fr
Le mur comme canevas. Transformez votre mur en œuvre d'art grâce à nos cimaises.



LIVING ROOM



- ❶ P8030 p.106
- ❷ C344 p.95
- ❸ P8020 p.106
- ❹ P4020 p.106
- ❺ SX118 p.120

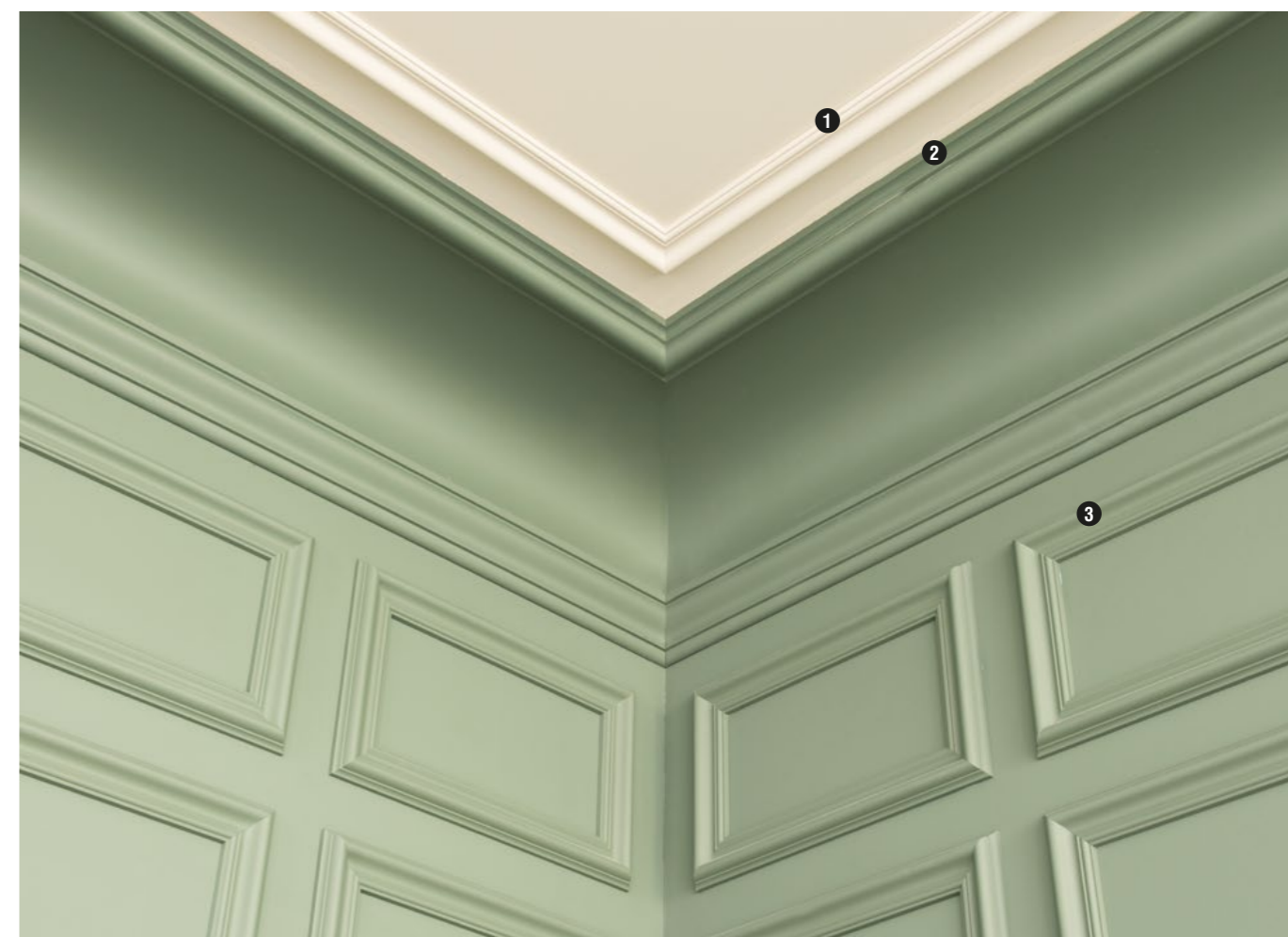

Instant
class.

Panelling
will take your space
to the next level.

ru

Мгновенный эффект.
Оформление пространства
молдингами поможет Вам
перейти на следующий
уровень.

pl

Efekt będzie natychmiastowy.
Nasze listwy przeniosą twoją
przestrzeń na wyższy poziom.

ar

أناقة فورية.
تليسة الجدران تعطي المساحة بعدا آخر.

fr

La classe instantanée.
Un lambris discret
élève l'espace.



Make spaces appear higher.

Paint the cornice moulding
along with the ceiling.

ru

Сделайте пространство
визуально выше.
Окрасьте карниз в один цвет с
потолком.

pl

Spraw, aby pomieszczenia
optycznie wyglądały na wyższe.
Pomaluj listwy karniszowe na ten
sam kolor co sufit.

ar

إجعلوا الغرفة تبدو أكثر ارتفاعاً.
إدهنوا الكورنيش والسقف باللون ذاته.

fr

Agrandissez visuellement
votre espace.
Peignez les corniches dans la
même couleur que le plafond.

LIVING ROOM

❶ C392 p.95

❷ PX116 p.110

❸ SX181 p.120

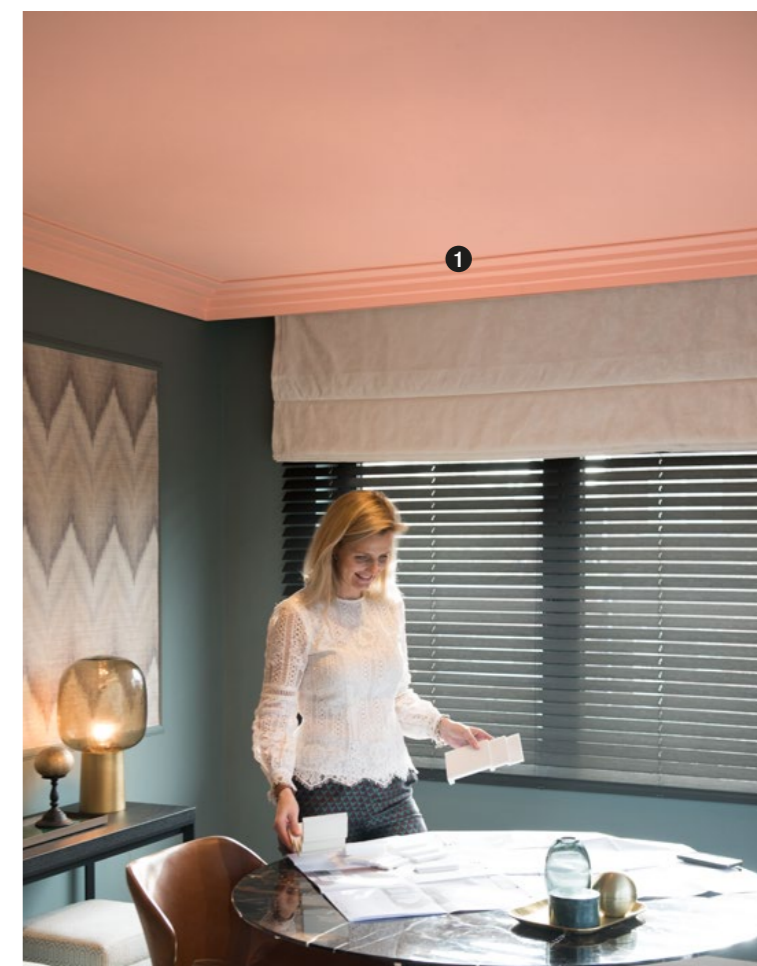
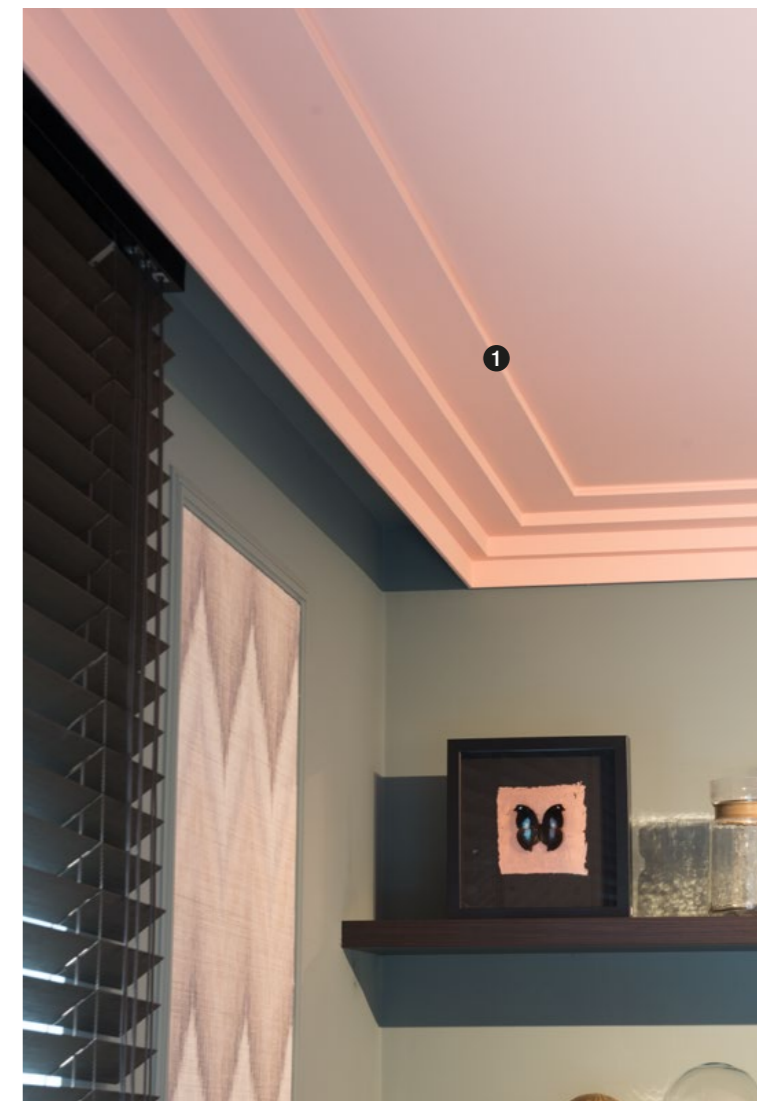



1 C354 p.86



1

LIVING ROOM



1

4:00pm *In the*
KITCHEN



PERSONALITY
IS THE BEST EXCUSE

Elegant transition.

Our cornice mouldings will tastefully hide any small imperfections between the wall and the ceiling.

1



2

KITCHEN

34



3

4

KITCHEN

3 C990 + 2x P9900

ru

Изящный переход.
Наши карнизы со вкусом скроют любые мелкие недостатки между стеной и потолком.

pl

Eleganckie przejście.
Nasze listwy karniszowe subtelnie ukryją wszelkie drobne niedoskonałości między ścianą a sufitem.

ar

تدرج أنيق.
الكرانيش تخفي العيوب الصغيرة بين الجدار والسقف.

fr

Transition élégante.
Nos corniches dissimulent subtilement les petites imperfections entre le mur et le plafond.

1 C991 p.89

2 SX180 p.120

3 C990 + 2x P9900 p.92

4 SX181 p.120

KITCHEN



- ❶ C344 p.95
- ❷ P8030 p.106
- ❸ P4020 p.106
- ❹ SX118 p.120



❹ SX118

KITCHEN

- ❶ CB503 p.101
- ❷ DX157-2300 p.150
- ❸ SX162 p.111
- ❹ PX120 p.111
- ❺ R66 p.146



ru

Графические линии и узоры подчеркнут интерьер.

pl

Graficzne linie i wzory podkreślą wystrój twojego wnętrza.

ar

الخطوط الجرافيكية تبرز المساحة الداخلية.

fr

Les lignes et les modèles graphiques rendent votre intérieur plus dynamique.

Graphic lines and patterns

accentuate the interior.





KITCHEN



ru

Будьте оригинальнее.
Кто сказал, что установить молдинги возможно только внизу стены?

pl

Bądź oryginalny.
Kto powiedział, że panele muszą być ułożone do samego dołu?

ar

كونوا مبدعين.
من قال أن التليسة يجب أن تكون على اسفل الجدار؟

fr

Soyez original.
Qui a dit que les lambris devaient aller au fond ?

Be original.

Who says panelling has to go at the bottom?

❶ C217 p.88

❷ PX113 p.111

❸ SX137 p.119



Stately cornice mouldings

are the perfect finish
for your space.

ru

Торжественные карнизы станут идеальной финишной отделкой пространства.

pl

Okazale listwy karniszowe są idealnym wykończeniem każdej przestrzeni.

ar

الكرانيش الفخمة تضيفي على المساحة اللمسة النهائية المثالية.

fr

Des corniches imposantes terminent parfaitement votre espace !

KITCHEN



1 C343 p.94

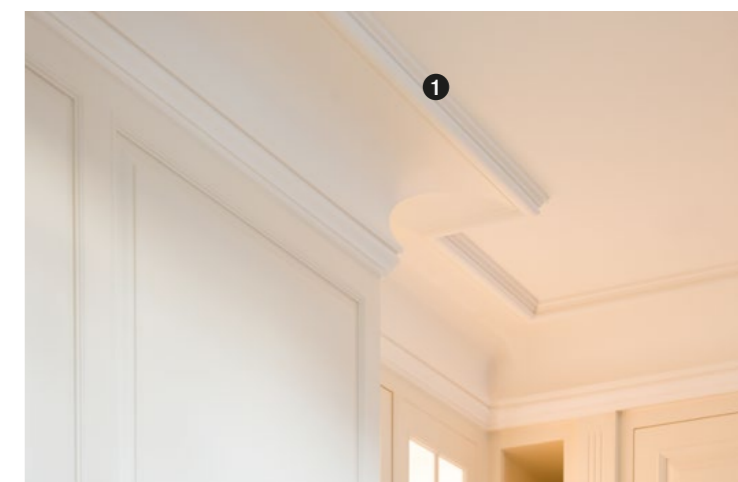

WEAR YOUR
PERSONALITY
WITH PRIDE



11:00am *In the*
BATHROOM

❶ DX174-2300 p.150

❷ PX175 p.111

❸ D340 p.150

❹ SX173 p.119

BATHROOM



Water-resistant. ——— Your bathroom deserves a beautiful finish too.

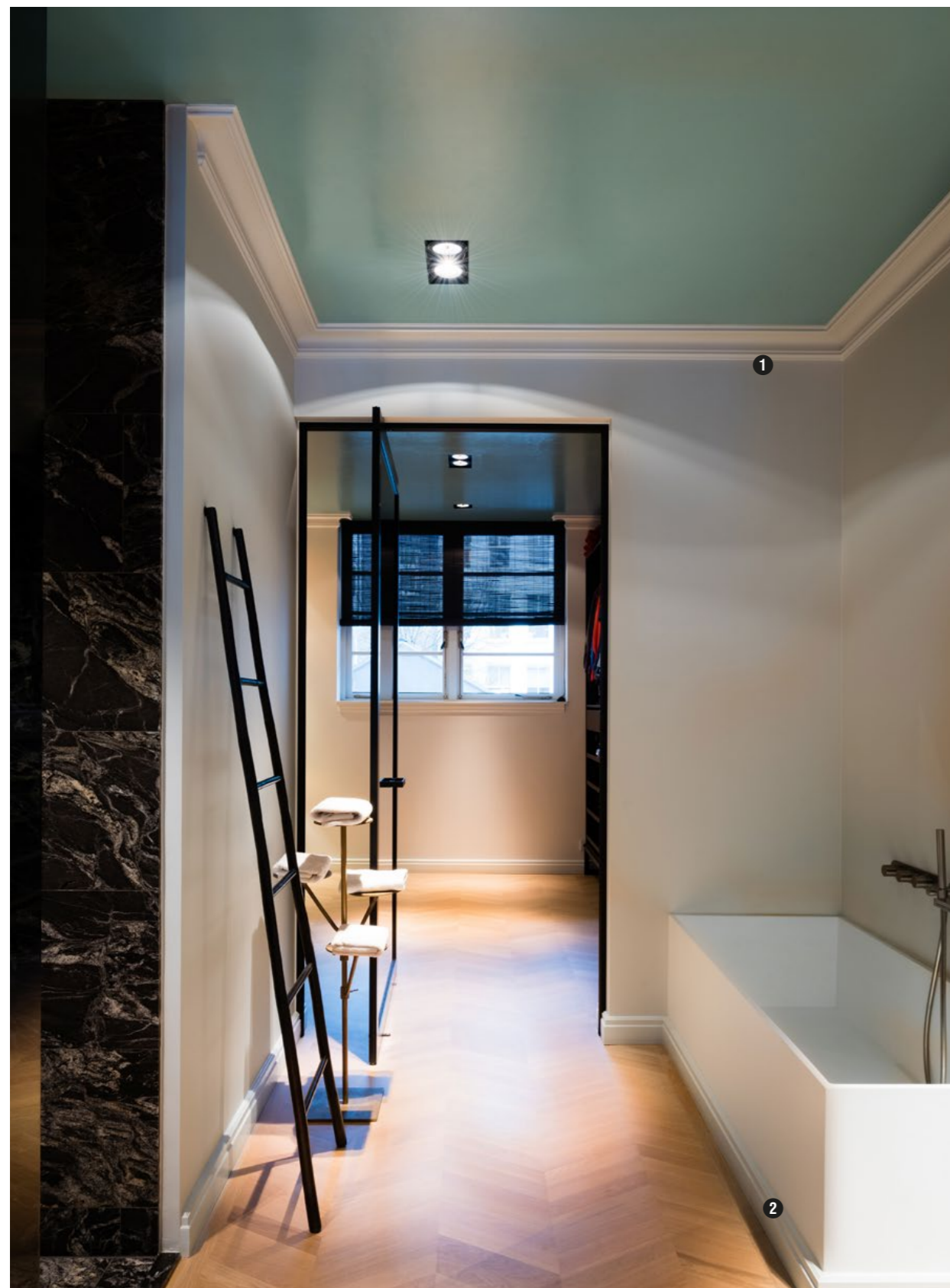

ru

Не бояться воды.
Ваша ванная комната тоже заслуживает красивую отделку.

pl

Wodoodporne.
Twoja łazienka również zasługuje na piękne wykończenie.

ar

مقاومة للماء
حمامكم أيضا يستحق أن يكون له مظهر جميل.

fr

Résistant à l'eau.
Votre salle de bains aussi mérite une jolie finition !

❶ C341 p.88

❷ SX155 p.119

❸ SX181 p.120

BATHROOM

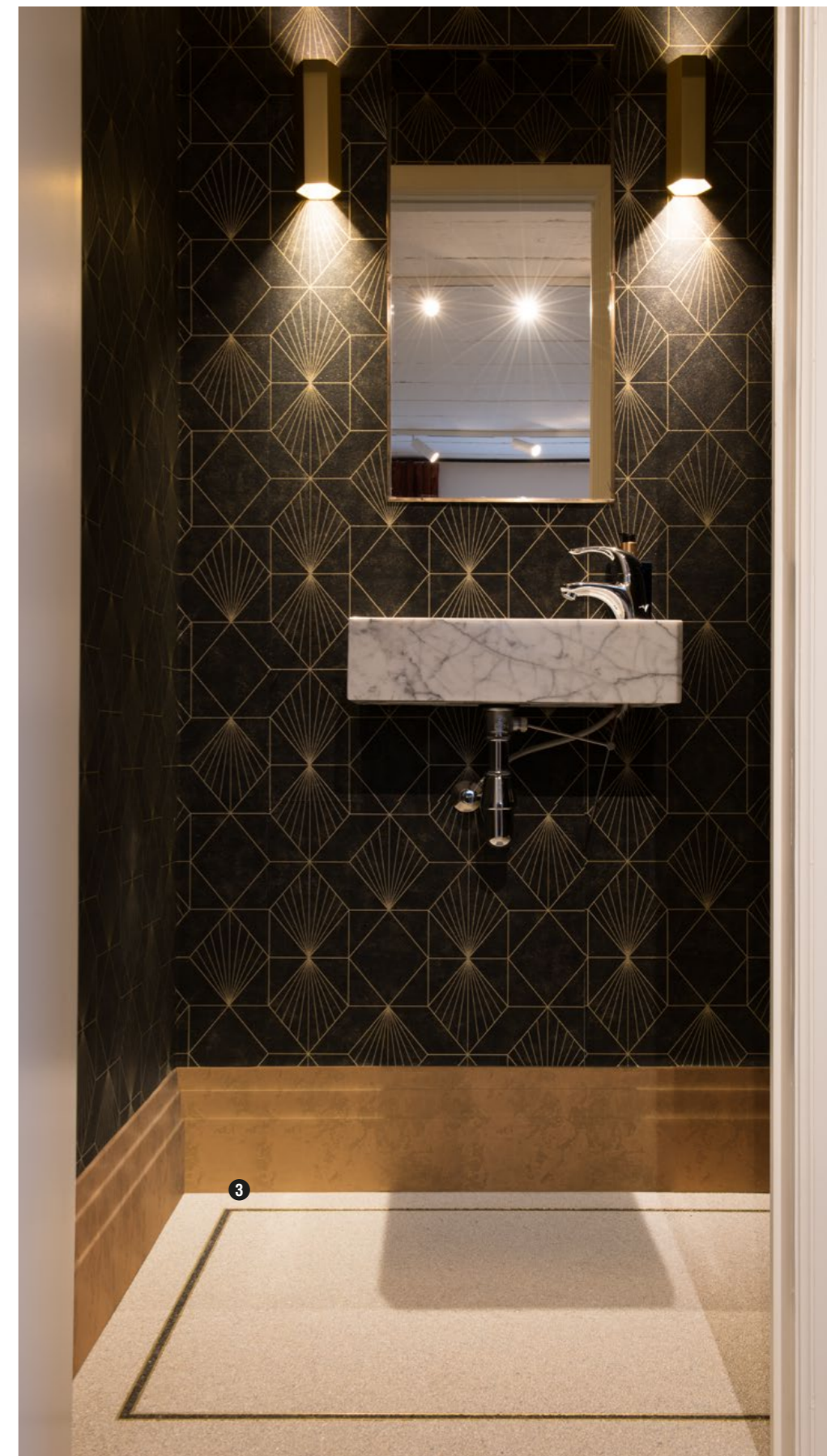

Go multifunctional.

Give your
entire space
a consistent,
sleek look.

ru

Выберите
многофункциональность.
Создайте Вашему
пространству концептуальный
и цельный вид.

pl

Podążaj za wielofunkcyjnością.
Nadaj całej przestrzeni spójny,
elegancki wygląd.

ar

استعملوا القوالب المتعددة الإستعمالات.
امنحوا المساحة بأكملها مظهرا متسقا
وأنيقا.

fr

Osez le multifonctionnel !
Créez une unité et donnez un
look épuré à votre espace.



1 DX159-2300 p.150

2 SX162 p.98

3 C393 p.90

4 SX181 p.120



3 C393



BATHROOM



BATHROOM



- ❶ C341 p.88
- ❷ P8050 p.108
- ❸ SX118 p.120

PERSONALITY

DESERVES A
PRIVATE SPACE



2:00pm *In the*
BEDROOM

BEDROOM

Good
night.

Turn your bedroom
into a true gem.



- 1 CX127 p.100
- 2 PX120 p.111
- 3 PX103 p.110
- 4 PX116 p.110
- 5 SX137 p.119

ru
Доброй ночи.
Превратите свою спальню в жемчужину.

pl
Dobranoc.
Zmień swoją sypialnię w prawdziwą perłę.

ar
طابت ليلتكم.
حولوا غرفة نومكم إلى جوهرة حقيقية.

fr
Bonne nuit.
Transformez votre chambre à coucher en un véritable petit paradis.

BEDROOM

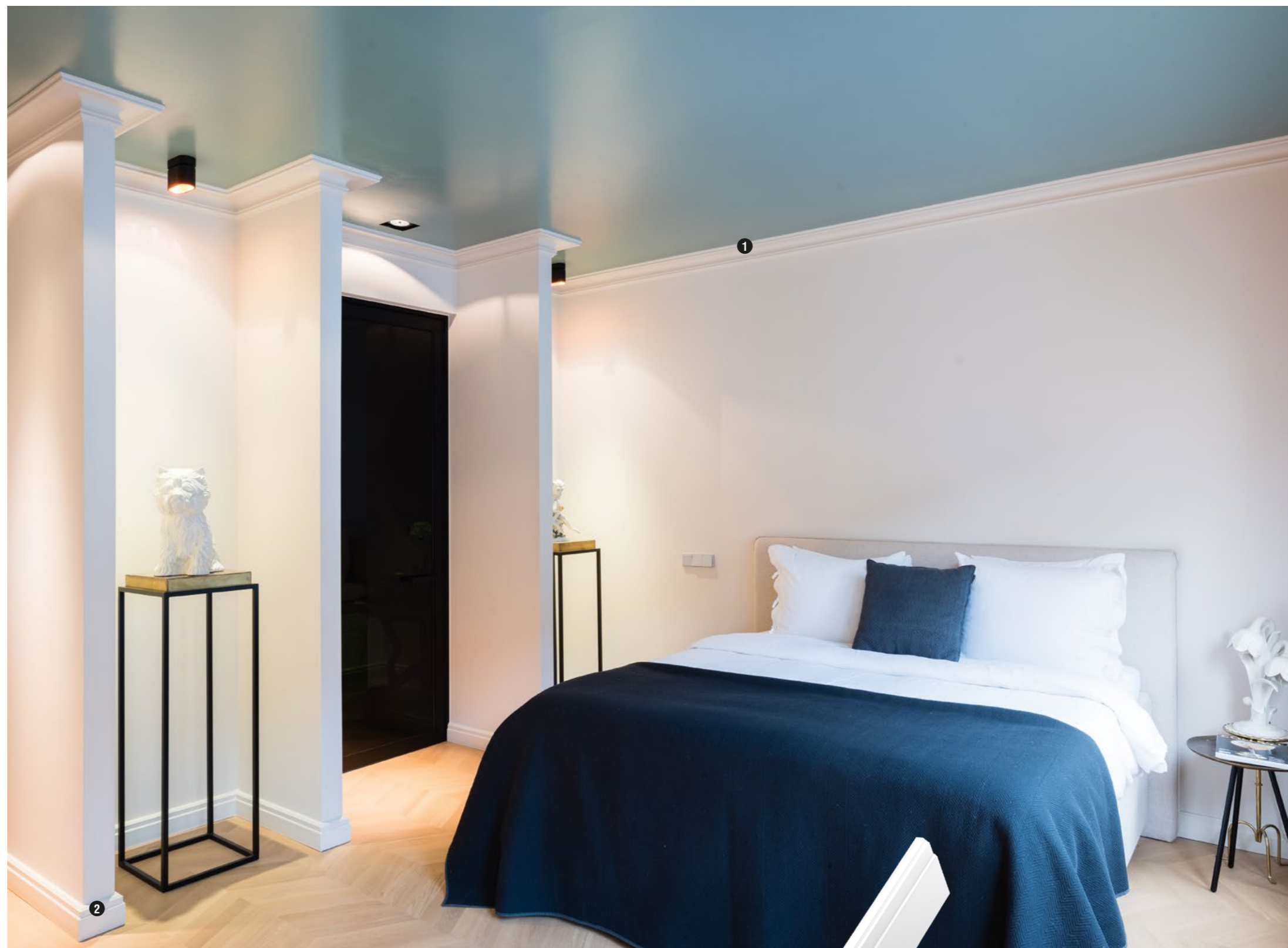

- 1 C341 p.88
- 2 SX155 p.119



2 SX155

Light up the room.

Indirect lighting will take your space
to a new level.



ru

Добавьте комнате света.
Скрытое освещение перенесёт
пространство на новый
уровень.

pl

Rozświetl pokój.
Pośrednie oświetlenie przeniesie
twoją przestrzeń na nowy
poziom.

ar

أضيئوا الغرفة.
الإضاءة غير المباشرة سوف تضيئ على
غرفتكم لمسة راقية.

fr

Illuminez la pièce.
L'éclairage indirect donne une
certaine classe à la pièce.

BEDROOM

❶ C990 + P9900 p.92

❷ C380 p.131

❸ C990 + 2x P9900 p.92



❸ C990 + 2x P9900



PROJECTS

Wake up in Palm Springs

— Casa Decor (es)



en

This interior takes you back to the iconic American architecture of the 1970s in Palm Springs. Interior specialist Patricia Bustos de la Torre gives this bedroom and bathroom the summer vibes of California with some soft pastels and curved shapes.

ru

Этот интерьер перенесёт Вас в прошлое к культовой американской архитектуре 1970-х в Палм Спрингс. Дизайнер интерьера Патрисия Бустос де ла Торре привнесла в спальню и ванную комнату летние волны Калифорнии с мягкими пастельными тонами и изогнутыми формами.

pl

To wnętrze przenosi cię do kultowej architektury z lat 70. w Palm Springs. Patricia Bustos de la Torre – specjalista ds. wystroju wnętrz, wykorzystując delikatne pastele i faliste kształty, nadaje tej sypialni i łazience letni klimat Kalifornii.

ar

هذه المساحة الداخلية تعود بكم إلى الهندسة المعمارية الأمريكية الشهيرة في السبعينات في بالم سبرينغز. تعطي الإختصاصية في التصميم الداخلي باتريشيا بوستوس دي لا توري غرفة النوم هذه وحمامها أجواء كاليفورنيا الصيفية بواسطة ألوان باستيل ناعمة وخطوط منحنية.

fr

Cet intérieur rappelle l'architecture américaine typique des années '70 à Palm Springs. La spécialiste de l'intérieur, Patricia Bustos de la Torre, traduit l'atmosphère estivale dans une chambre à coucher et dans une salle de bains à l'aide de doux tons pastel et de courbes.

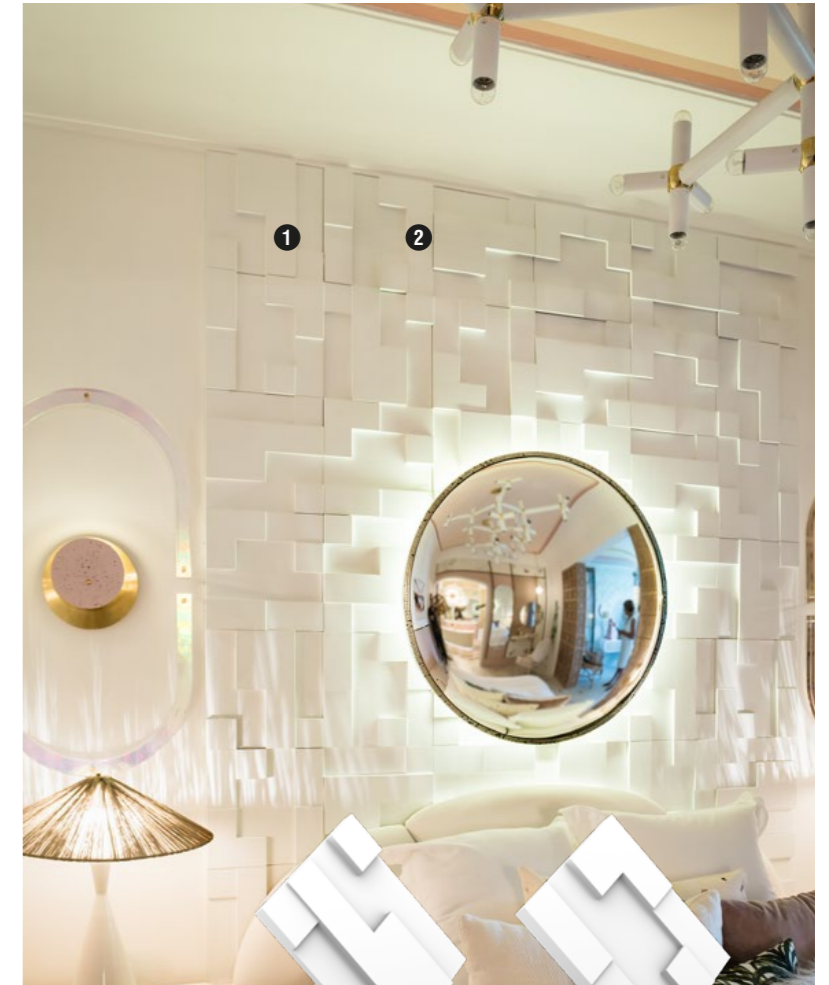

- 1 W102 p.142
- 2 W103 p.142
- 3 SX181 p.120
- 4 C392 p.95



Living Green

— Casa Decor (es)

en

Interior architects Inmaculada Recio and Silvia Trigueros presented their 'Living Green' suite at Casa Decor 2017 in Madrid. Their aim was to combine masculine and feminine styles in this stylish suite. They united the best of both worlds to create a classy, lively interior.

ru

Дизайнеры интерьера Инмакулада Ресю и Сильвия Тригуерос представили свой проект «Living Green» на выставке Casa Decor 2017 в Мадриде. Целью дизайнеров было объединить в одном стильном номере Люкс мужское и женское начало. Они взяли лучшее из обоих миров для создания классного, живого интерьера.

pl

Architekci wnętrz Inmaculada Recio i Silvia Trigueros na Casa Decor 2017 w Madrycie zaprezentowali swój apartament «Living Green». Ich celem było połączenie w tym modnym pomieszczeniu stylu męskiego i kobiecego. Połączyli to, co najlepsze z obu tych światów, aby stworzyć elegancki, żywy wystój wnętrza.

ar

قدمت المهندستان المعمارتان الداخيلتان إنماكولادا ريسيو وسيلفيا تريغيروس جناح "living green" في كازا ديكور ٢٠١٧ في مدريد. كان هدفهما دمج الأنماط الذكورية والأنثوية في هذا الجناح الأنيق. قامتا بجمع أفضل ما في العالمين لخلق ديكور داخلي أنيق وحيوي.

fr

Pendant Casa Decor 2017 à Madrid, les architectes d'intérieur Inmaculada Recio et Silvia Trigueros ont présenté leur suite "Living Green". Cette suite élégante avait pour objectif d'associer le style masculin et féminin. Elles ont combiné le meilleur des deux mondes et ont créé un intérieur élégant et énergique.

1 C393 p.90

2 C356 p.86

3 CX160 p.98

4 SX181 p.120



De Huiskamer

— Roeselare (be)



en

The inviting interior of this restaurant in Roeselare is bursting with personality. A multitude of roses on the ceiling add character to the property.

ru

Привлекательный интерьер ресторана в бельгийском городе Roeselare взрывается от своей оригинальности. Множество потолочных розеток добавляет темперамент этому помещению.

pl

Przytulne wnętrze tej restauracji w Roeselare pełne jest osobowości. Mnóstwo róż na suficie dodaje charakteru nieruchomości.

ar

الداخل الجذاب لهذا المطعم في روزيلار مفعم بالشخصية. وردات السقوف العديدة تضيف طابع مميز إلى المكان.

fr

Ce sympathique restaurant à Roulers intègre sans aucun doute de la personnalité dans son intérieur ! Pas une, mais une multitude de rosaces décorent le plafond et donnent une touche de peps supplémentaire à l'immeuble !

1 R10 p.145

2 R31 p.145

3 R17 p.145

4 R52 p.146



Essentiel

— Antwerp (be)

- 1 C990 p.92
- 2 C322 p.86
- 3 SX155 p.119

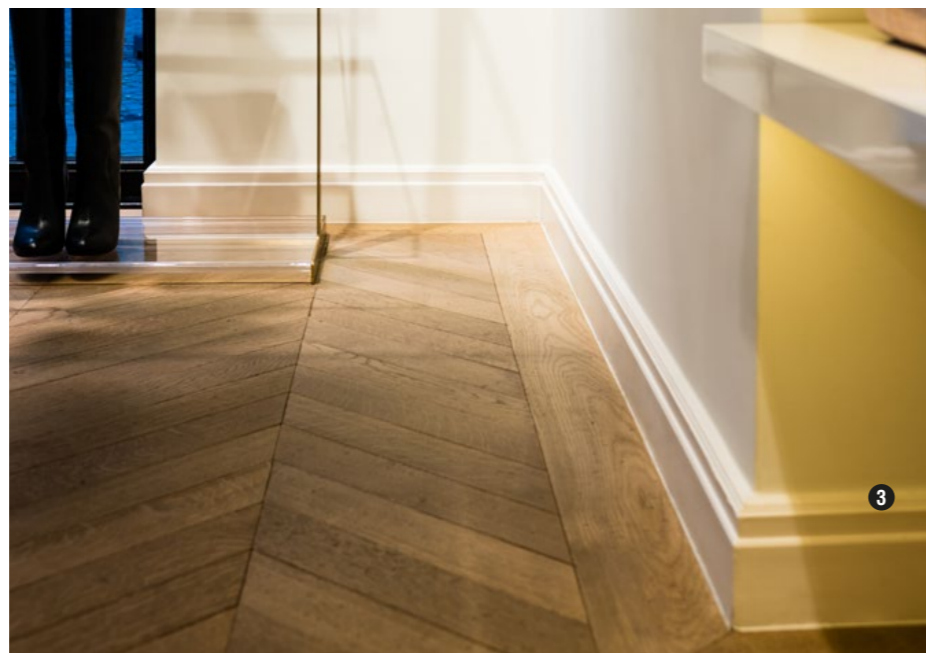

- 1 C342 p.90

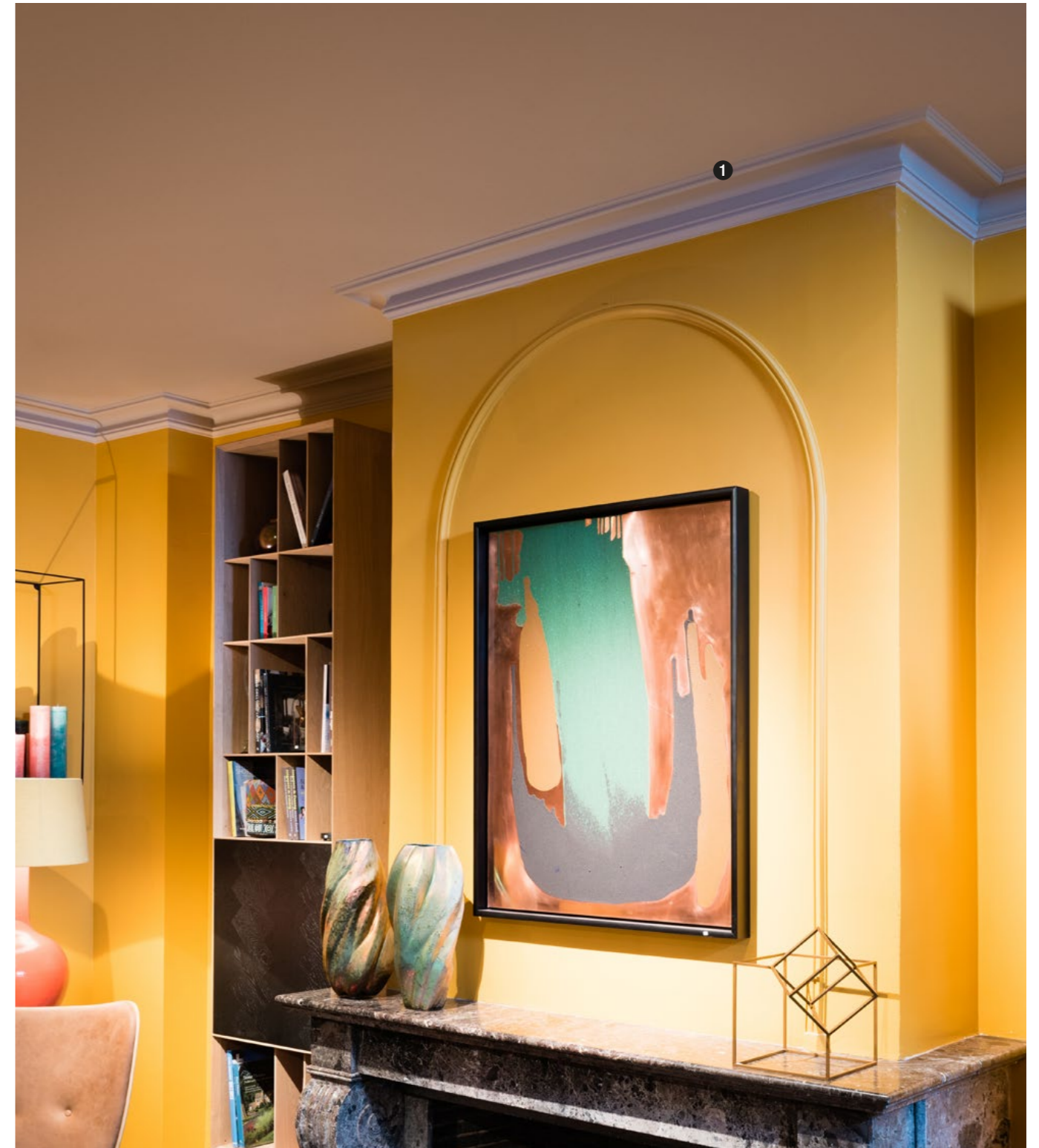

Frederiek Van Pamel

— Bruges (be)

Hotel Das Tegernsee

— Tegernsee (de)



- ❶ PX120 | PX120F p.111
- ❷ CX127 p.100
- ❸ P8020 p.106

en

The playful ceiling of the Hotel Tegernsee dining area leaves an instant impression. The creative use of our flexible mouldings shows how versatile it is.

ru

Игривый потолок ресторана отеля Tegernsee оставляет мгновенный отпечаток. Творческое использование наших гибких молдингов показывает, насколько они универсальны.

pl

Zabawny sufit w jadalni hotelu Tegernsee robi błyskawicznie wrażenie. Kreatywne wykorzystanie naszych giętkich listew pokazuje, jak bardzo może być wszechstronne.

ar

السقف اللعوب للقاعة تناول الطعام في فندق تيجرنسي يحدث انطباعاً فوراً. الاستخدام المبتكر للقوالب المرنة يظهر تعدد إستعمالاتها.

fr

Grâce à son plafond aérien, l'espace restaurant de l'hôtel Tegernsee vous procure un effet waouh instantané. Nos moulures flexibles ont été placées de façon originale pour exposer leurs nombreuses possibilités d'utilisation.



The Mint

— Madrid (es)

en

The interior of this hotel certainly lives up to its name. The cool green hues throughout the hotel create a trendy, yet sophisticated ambience. The lines of the Orac Decor® mouldings complete the picture.

ru

Интерьер этого отеля безусловно отсылает к своему имени. Прохладные зелёные оттенки во всех помещениях отеля создаёт модную, немного сложную атмосферу. Завершают картину линии молдингов Orac Décor®.

pl

Wnętrze tego hotelu w pełni odzwierciedla jego nazwę. Chłodne zielone odcienie w całym hotelu tworzą modną, finezyjną atmosferę. Linie listew Orac Décor® uzupełniają ten obraz.

ar

إن داخل هذا الفندق يتطابق بالتأكيد مع اسمه. تخلق الألوان الخضراء الباردة في جميع أنحاء الفندق أجواءً عصرية وراقية. وتكتمل الصورة مع خطوط قوالب أوراك ديكور.

fr

L'intérieur de cet hôtel fait parfaitement honneur à son nom. Les teintes froides de vert à travers l'hôtel procurent une ambiance branchée et raffinée. Le jeu de lignes créé à l'aide des moulures Orac Décor® complète le tableau.

❶ C200 p.87

❷ PX117 p.111





The Hoxton

— Paris (fr)

en

The ornate façade and cast-iron balconies of the hotel exude pure class. Inside the rooms, the panelling and cornice mouldings accentuate the sense of grandeur, as does the interplay between the various colours.

ru

Декоративный фасад и чугунные решётки на балконах соответствуют высшему классу этого отеля. Оформление комнат молдингами и карнизами, а также игра цветов подчёркивают окружающее великолепие.

pl

Ozdobna fasada i żeliwne balkony hotelu emanują czystą, nieskazitelną klasą. Wnętra pokoi, panele i listwy przysufitowe podkreślają poczucie wielkości, jakie wywołuje połączenie różnych kolorów.

ar

واجهة الفندق المزخرفة وشرفاته الحديدية تشع بالأناقة. القوالب والكرانش داخل الغرف، وكذلك التفاعل بين مختلف الألوان، يعزز الشعور بالفخامة.

fr

L'hôtel majestueux, avec ses balcons en fer forgé et sa façade joliment décorée, exprime une élégance rare. Les lambris et les corniches, combinés au jeu de couleurs, prolongent cette impression de grandeur dans les chambres.



Ruin Revival

— London (uk)



- ❶ P7010 p.108
- ❷ P3020 p.106
- ❸ P8040 p.108
- ❹ P8030D p.113
- ❺ P3020A p.113



Materials

МАТЕРИАЛЫ / MATERIAŁY
داوم ل / MATÉRIAUX

PUROTOUCH®

A high-quality, high-density polyurethane that allows fine details.

Высококачественный полиуретан высокой плотности позволяет создавать мелкие детали.

Wysokiej jakości, o dużej gęstości poliuretan pozwala uzyskać drobne szczegóły.

بوليوريثين عالي الجودة، عالي الكثافة يسمح بالحصول على تفاصيل دقيقة.

Un polyuréthane de qualité à haute densité qui permet de créer des détails fins.

FLEX

A wide range of cornice mouldings, panel mouldings and skirting boards are also available in a flexible polyurethane version.

Широкий ассортимент карнизов, молдингов и плинтусов также представлен в своих гибких аналогах.

Szeroka gama listew przysufitowych, przyściennych i przypodłogowych dostępna jest również w wersji giętej.

مجموعة واسعة من الكرائيش، قوالب الجدران والتعلات متوفرة بصيغة مرنة.

De nombreuses corniches, cimaises et plinthes sont disponibles dans des modèles variés en polyuréthane.

DUROPOLYMER®

An extruded and impact-resistant polymer based on a high-density polystyrene.

Экструдированный и ударопрочный полимер на основе полистирола высокой плотности.

Tłoczony, odporny na uderzenia polimer powstały na bazie polistyrenu o wysokiej gęstości.

بوليمر مبثوق ومقاوم للصددمات، من مزيج بوليستيرين عالي الكثافة.

Un polymère extrudé résistant aux impacts à base d'un mélange de polystyrènes haute densité.

DUROFOAM®

An extruded lightweight polymer based on a medium-density polystyrene blend.

Экструдированный легкий полимер на основе полистирольной смеси средней плотности.

Lekki, tłoczony polimer na bazie mieszanki polistyrenów o wysokiej gęstości.

بوليمر مبثوق وخفيف الوزن، من مزيج بوليستيرين متوسط الكثافة.

Un polymère léger extrudé à base d'un mélange de polystyrènes de densité moyenne.



	Detail Design	Impact Resistance
PUROTOUCH®	☆☆☆	☆☆
DUROPOLYMER®	☆☆	☆☆☆
DUROFOAM®	☆	☆

Product Overview

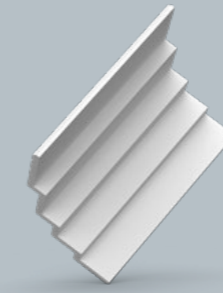

Cornice Mouldings

Карнизы / Gzymsy / کرانش / Corniches
Pg. 84

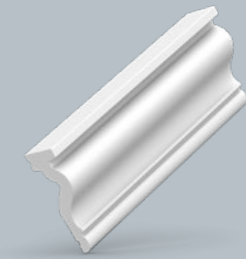

Panel Mouldings

Молдинги / Profile Ścienne
قوالب للجدران / Cimaises
Pg. 104



Skirting

Плинтусы / Listwy Przyścielowe
نعلات / Plinthes
Pg. 114

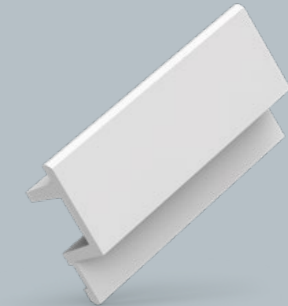

Indirect Lighting

Скрытое Освещение / Listwy Oświetleniowe
إضاءة غير مباشرة / Éclairage Indirect
Pg. 126



Deco Elements

Декоративные Элементы
Elementy Dekoracyjne
أصناف للزينة / Éléments Décoratifs
Pg. 138



The Perfect Finish

Идеальный Финиш / Idealne Wykończenie
مظهر نهائي مثالي / La Finition Parfaite
Pg. 154

Cornice Mouldings

КАРНИЗЫ / GZYMSY
كرانيش / CORNICHES

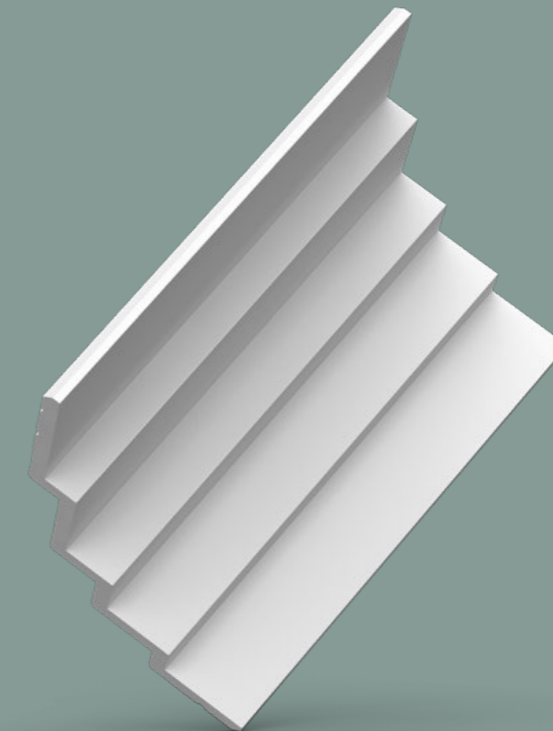
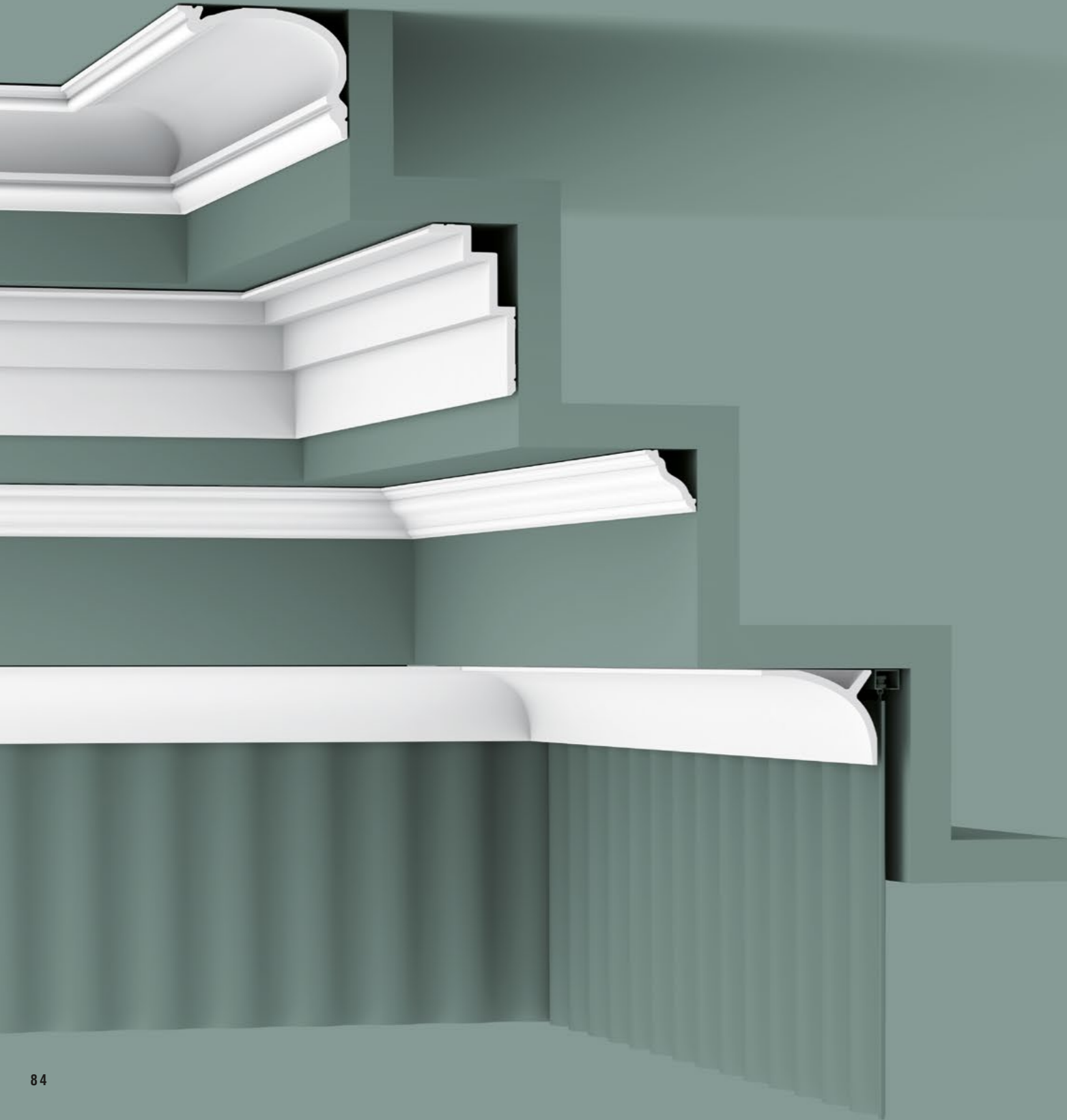

en

A cornice creates a visually attractive transition from wall to ceiling. From sleek to baroque, from decorative to functional – we offer a quality solution for every budget. The profiles are easy to install, and a large number of designs are available in flexible versions.

ru

Карниз создает визуально привлекательный переход от стены к потолку. От гладких профилей до Барокко, от декоративных до функциональных - мы предлагаем качественное решение на любой бюджет. Профили легко монтировать. Большое количество дизайнов представлены также в гибком виде.

pl

Gzymsy tworzą wizualnie atrakcyjne połączenie pomiędzy ścianami i sufitem. Od gładkich do barokowych, od dekoracyjnych do funkcjonalnych – oferujemy wysokiej jakości rozwiązania na każdą kieszeń. Gzymsy Orac są łatwe do instalacji, a wiele naszych wzorów jest dostępnych w wersji elastycznej.

ar

كورنيش تخلق إنتقال جذاب بين الحائط والسقف. من التصميم الأنيق الى الباروك، من الزيني الى العملي، نحن نقدم حلول عالية الجودة لكل الميزانيات. القوالب سهلة التركيب، وعدد كبير منها متوفر أيضا بصيغة مرنة.

fr

Une moulure ajoute un effet visuellement intéressant à la transition entre mur et plafond. Quel que soit votre budget, nous vous proposons une solution de qualité : du style minimaliste au baroque, de l'élément décoratif au fonctionnel. Les profils sont faciles à poser, et un grand nombre de produits sont également disponibles en version flexible.



C250 | C250F
200 x 1,6 x 1,6 cm
Purotouch®



C360
200 x 2,1 x 6 cm
Purotouch®
Designed by
Jacques Vergracht



C356
200 x 2 x 10 cm
Purotouch®
Designed by
Jacques Vergracht



C602 | C602F
200 x 5,3 x 5 cm
Purotouch®

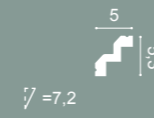

C323
200 x 5,5 x 4,2 cm
Purotouch®



C230 | C230F
200 x 2,9 x 2,9 cm
Purotouch®



C353
200 x 3 x 16,5 cm
Purotouch®
Designed by
Jacques Vergracht



C394 STEPS
200 x 3,1 x 9,5 cm
Purotouch®
Designed by
Orio Tonini

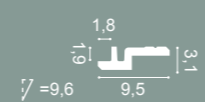

C400
200 x 6 x 10 cm
Purotouch®



C390 STEPS
200 x 6 x 10 cm
Purotouch®
Designed by
Orio Tonini

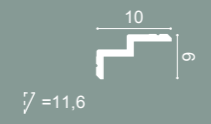

1 C327 p.91



C395 STEPS
200 x 3,1 x 15,5 cm
Purotouch®
Designed by
Orio Tonini

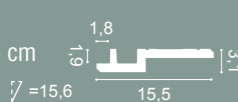

C355
200 x 3,5 x 11,1 cm
Purotouch®
Designed by
Jacques Vergracht

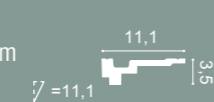

C354
200 x 4 x 21,5 cm
Purotouch®
Designed by
Jacques Vergracht



C396 STEPS
200 x 6,1 x 18,5 cm
Purotouch®
Designed by
Orio Tonini

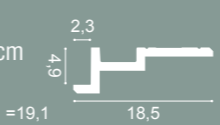

C391 STEPS
200 x 6 x 16 cm
Purotouch®
Designed by
Orio Tonini



C331 | C331F
200 x 6,4 x 13,5 cm
Purotouch®

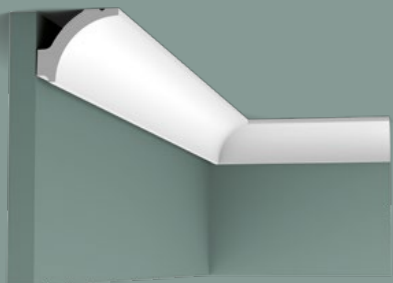

C260 | C260F
200 x 4,1 x 4,8 cm
Purotouch®



C215 | C215F
200 x 4,7 x 4,7 cm
Purotouch®

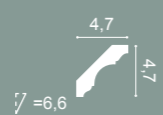

C322 | C322F
200 x 5 x 4,2 cm
Purotouch®



C200 | C200F
200 x 6,5 x 5,7 cm
Purotouch®



C214 | C214F
200 x 6,6 x 3,1 cm
Purotouch®



C325 | C325F MANOIR
200 x 7 x 6,5 cm
Purotouch®

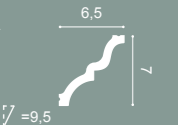



C212 | C212F
200 x 7,5 x 4,5 cm
Purotouch®

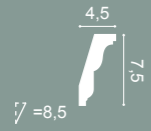

C220 | C220F
200 x 7,6 x 11,6 cm
Purotouch®

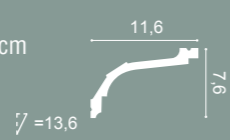

C213 | C213F
200 x 8 x 8 cm
Purotouch®

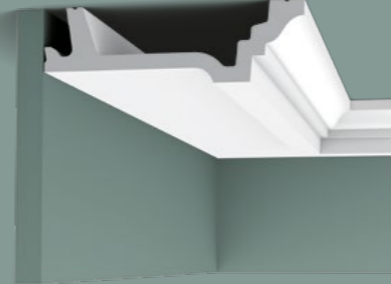

C305
200 x 4,7 x 15,5 cm
Purotouch®

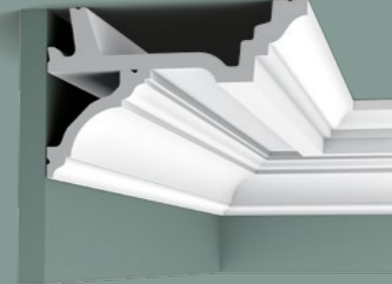

C305 + C213

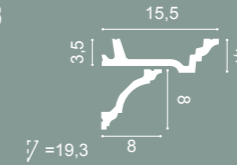

C305 + C211

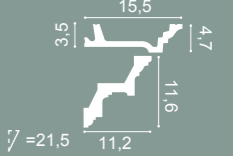

C240 | C240F
200 x 8 x 8 cm
Purotouch®

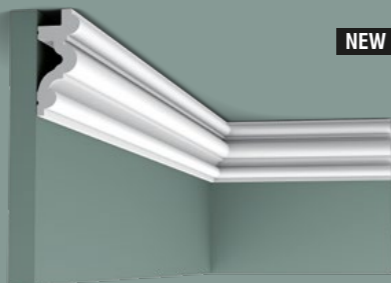
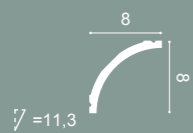

C324 AUTOIRE
200 x 8,3 x 3,4 cm
Purotouch®
Designed by
Orio Tonini



**C341 | C341F
HERITAGE**
200 x 8,8 x 12,2 cm
Purotouch®

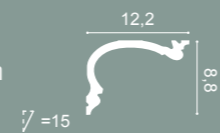

C991
200 x 11 x 14 cm
Purotouch®
Designed by
Ulf Moritz

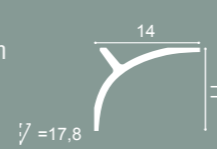

C991 + P9900

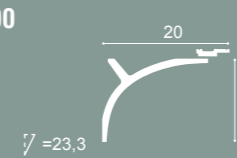

C991 + 2x P9900

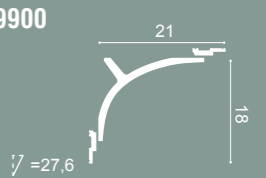

C321 | C321F
200 x 9,9 x 5 cm
Purotouch®

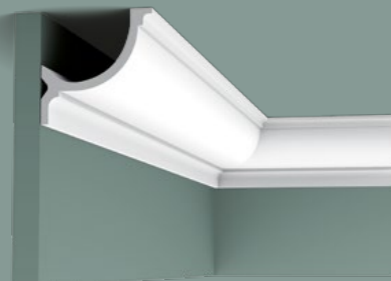
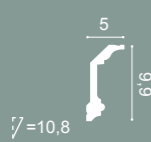

C902 | C902F
200 x 10,3 x 10,3 cm
Purotouch®



C217 | C217F
200 x 10,3 x 15,6 cm
Purotouch®

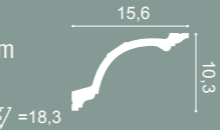

C991
200 x 14 x 11 cm
Purotouch®
Designed by
Ulf Moritz

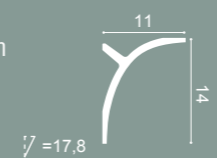

C991 + P9900

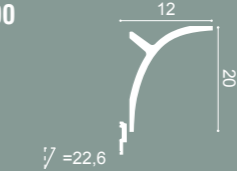

C217 | C217F
200 x 15,6 x 10,3 cm
Purotouch®

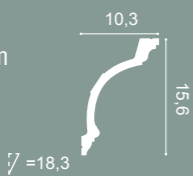

C326 | C326F MANOIR
200 x 10,5 x 9 cm
Purotouch®

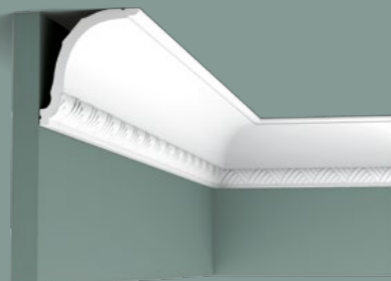
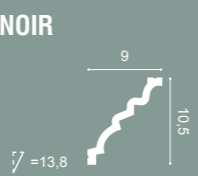

C402 | C402F
200 x 10,7 x 9,4 cm
Purotouch®

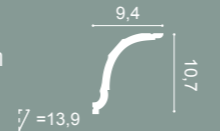

C991 + 2x P9900

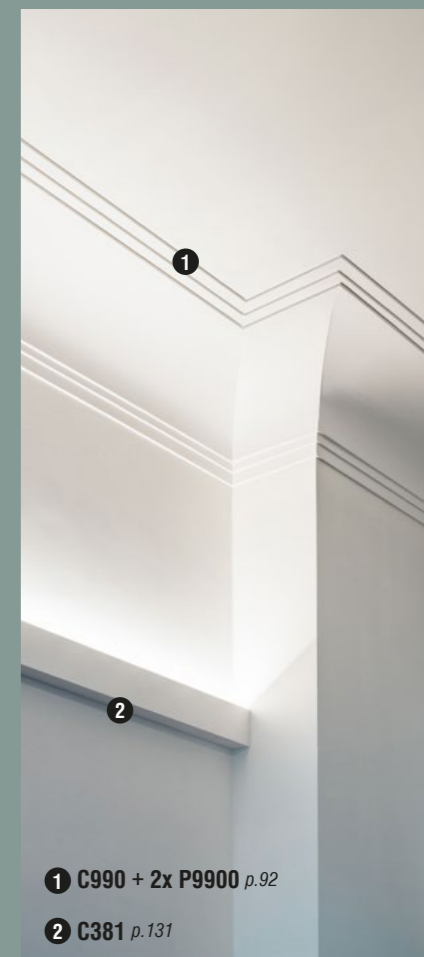
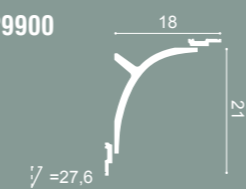

1 C990 + 2x P9900 p.92
2 C381 p.131

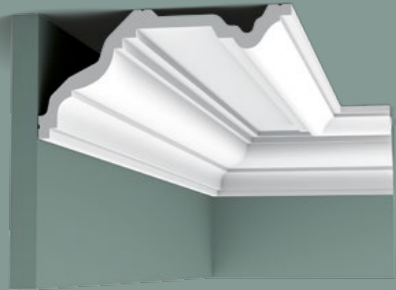

C332
200 x 11,4 x 23 cm
Purotouch[®]

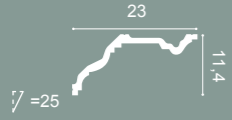

C332
200 x 23 x 11,4 cm
Purotouch[®]



C201 | C201F
200 x 11,6 x 4,8 cm
Purotouch[®]

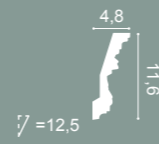

NEW

C327 MANOIR
200 x 14,3 x 15,9 cm
Purotouch[®]

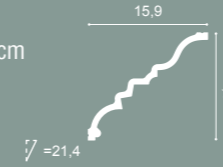

C303 | C303F
200 x 14,4 x 6,5 cm
Purotouch[®]

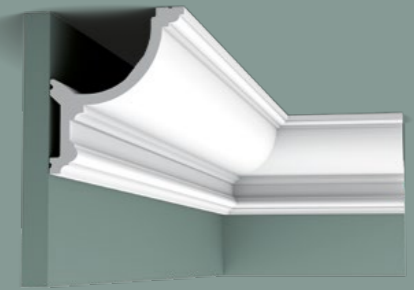
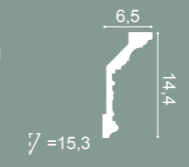

C901 | C901F
200 x 14,8 x 12,4 cm
Purotouch[®]

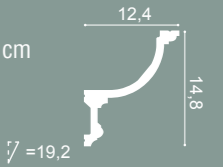

C211 | C211F
200 x 11,6 x 11,2 cm
Purotouch[®]

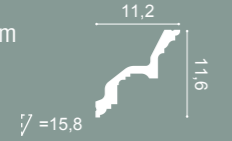

C216 | C216F
200 x 11,6 x 13,3 cm
Purotouch[®]

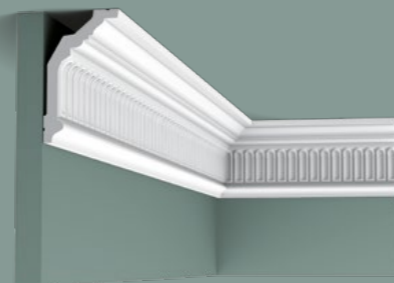

C304 | C304F
200 x 12,2 x 7,2 cm
Purotouch[®]

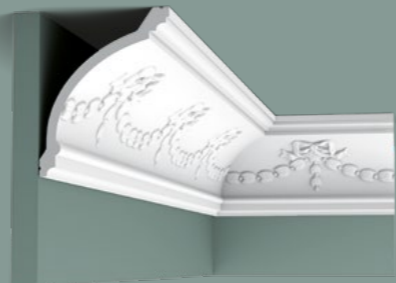
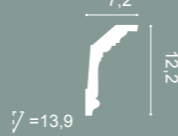

C218 | C218F
200 x 15 x 12 cm
Purotouch[®]

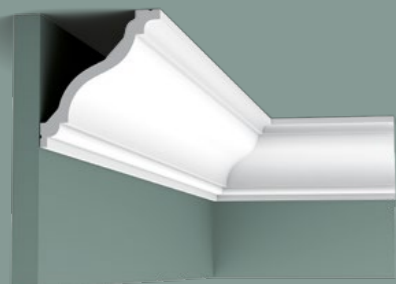
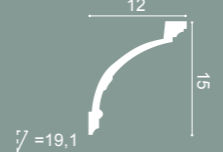

C333 | C333F
200 x 12,2 x 11,1 cm
Purotouch[®]

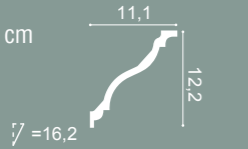

C302 | C302F
200 x 12,8 x 8,5 cm
Purotouch[®]



C342 HERITAGE
200 x 14 x 19 cm
Purotouch[®]

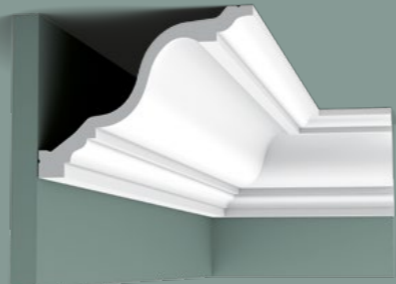
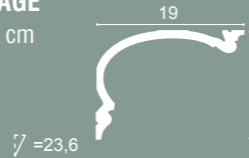

C334 | C334F
200 x 15 x 19,6 cm
Purotouch[®]

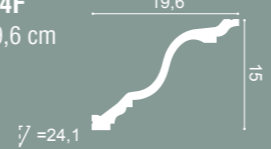

C340
200 x 25,6 x 13,5 cm
Purotouch[®]

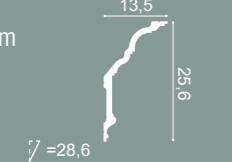

C340
200 x 13,5 x 25,6 cm
Purotouch[®]



C339 | C339F
200 x 14,1 x 6,4 cm
Purotouch[®]

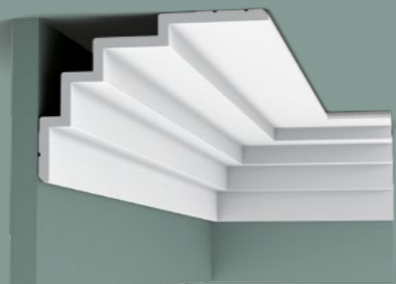
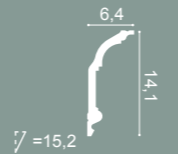

C393 STEPS
200 x 15 x 21 cm
Purotouch[®]
Designed by
Orto Tonini

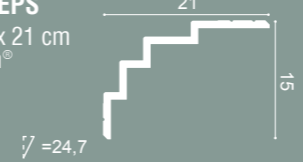

1 C343 p.94

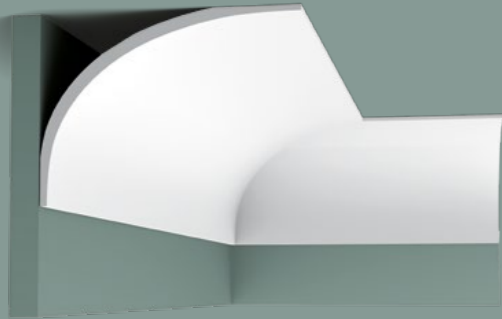

C990 INFINITY
200 x 15,9 x 21,6 cm
Purotouch®
Designed by
Xavier Donck

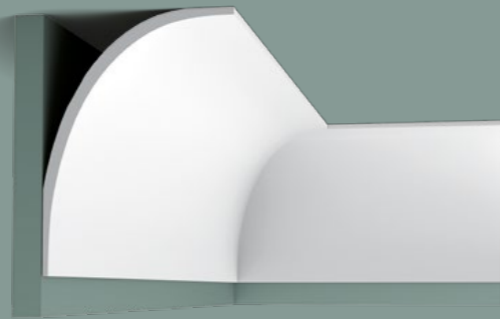

C990 INFINITY
200 x 21,6 x 15,9 cm
Purotouch®
Designed by
Xavier Donck

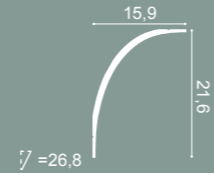

C422
200 x 16,4 x 19,4
Purotouch®

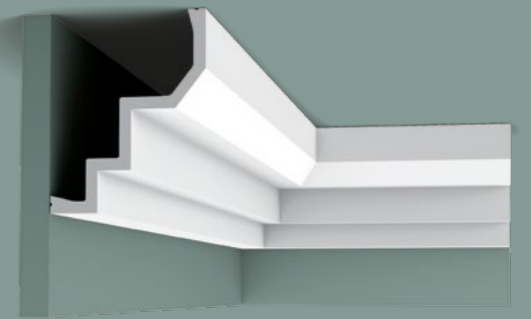
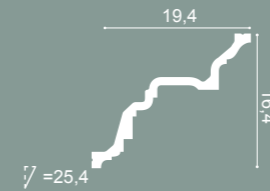

C300
200 x 16,5 x 13 cm
Purotouch®

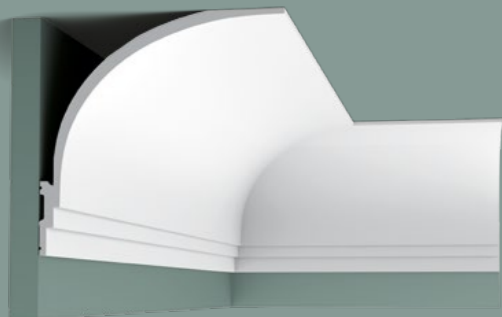
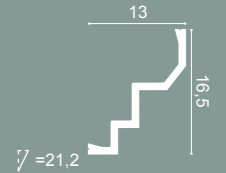

C990 + P9900

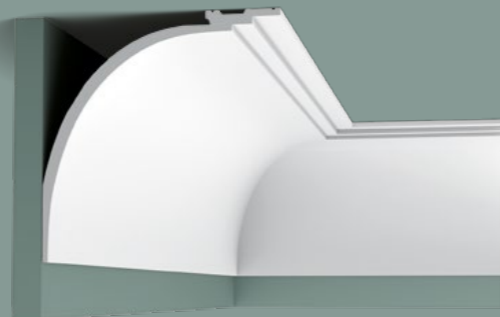
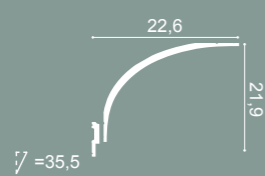

C990 + P9900

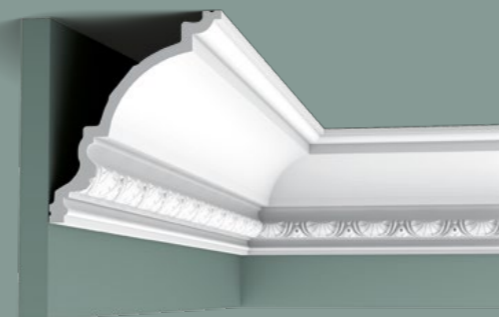
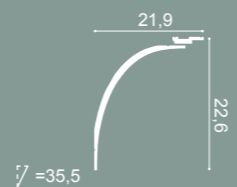

C301 | C301F
200 x 17 x 14,4 cm
Purotouch®

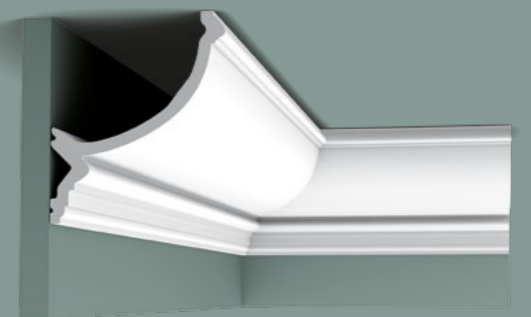
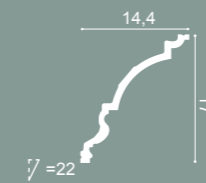

C900
200 x 17,1 x 14,6 cm
Purotouch®

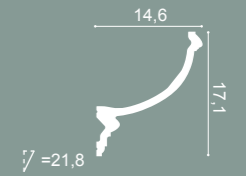

C990 + 2x P9900

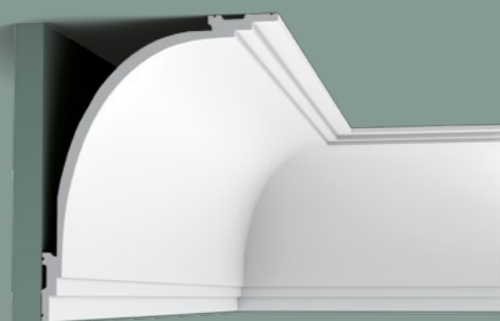
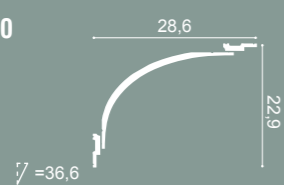

C990 + 2x P9900

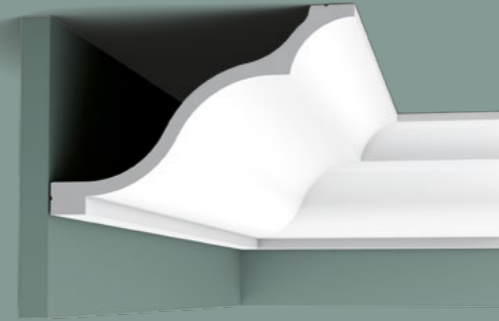
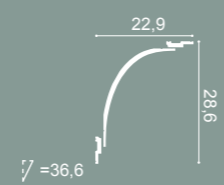

C337
200 x 17,2 x 25,6 cm
Purotouch®



C219
200 x 17,6 x 13 cm
Purotouch®

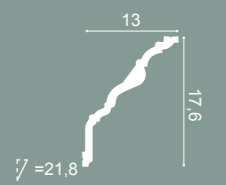

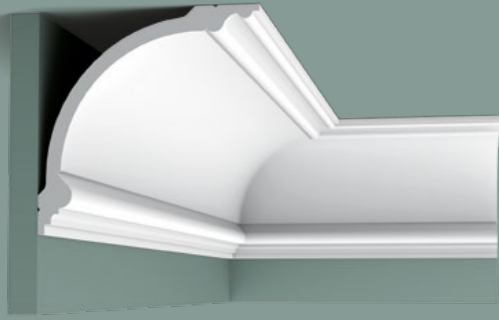

C338
200 x 18,4 x 18,4 cm
Purotouch®

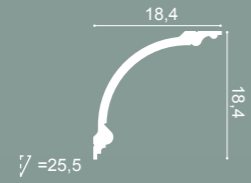

C338A BA'ROCK
200 x 18,4 x 18,4 cm
Purotouch®

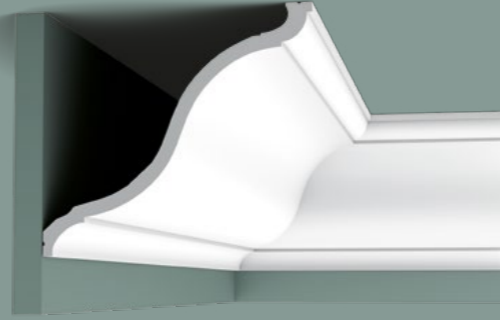
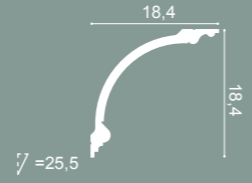

C335
200 x 20,2 x 22,2 cm
Purotouch®
Designed by
Xavier Donck

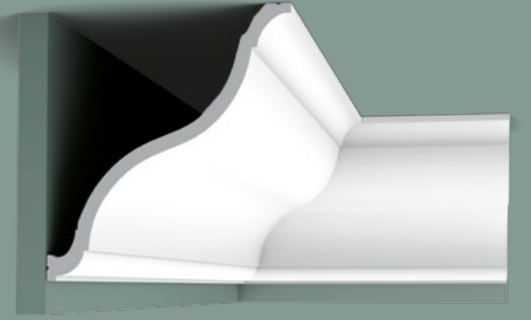
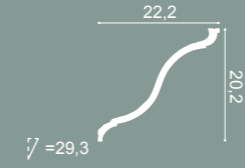

C335
200 x 22,2 x 20,2 cm
Purotouch®
Designed by
Xavier Donck

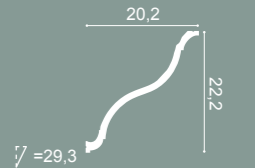

C338B BA'ROCK
200 x 18,4 x 18,4 cm
Purotouch®

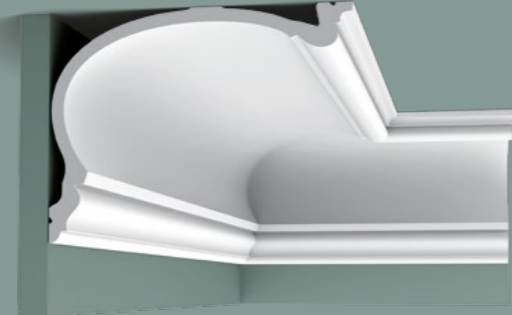
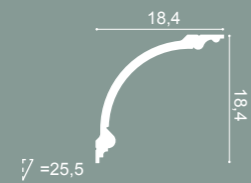

C343 HERITAGE
200 x 19 x 25 cm
Purotouch®

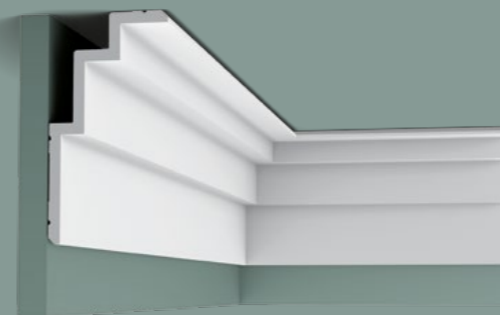
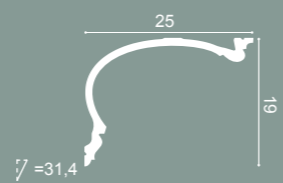

C392 STEPS
200 x 19 x 10 cm
Purotouch®
Designed by
Orio Tonini



C308 | C308F
200 x 24,8 x 6,3 cm
Purotouch®

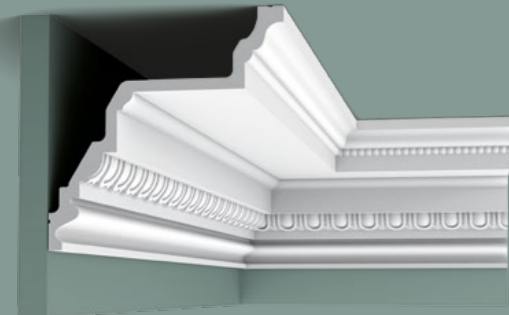
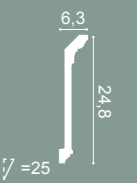

C307
200 x 19,5 x 19,5 cm
Purotouch®

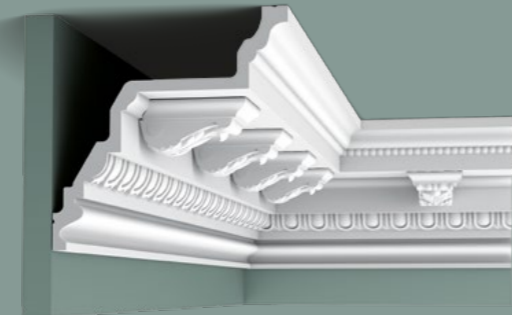
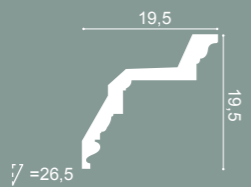

1 C307 + C307A 2
C307A: 7,5 x 4 x 9,4
Duropolymer®



C336
200 x 27,1 x 26,6 cm
Purotouch®

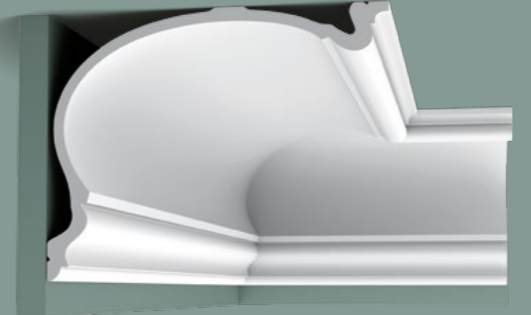
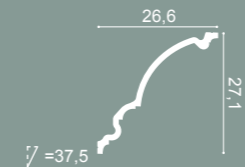

C344 HERITAGE
200 x 27,3 x 35 cm
Purotouch®



Steps



CORNICE MOULDINGS | КАРНИЗЫ | GZYMSY | كرائيش | CORNICHES

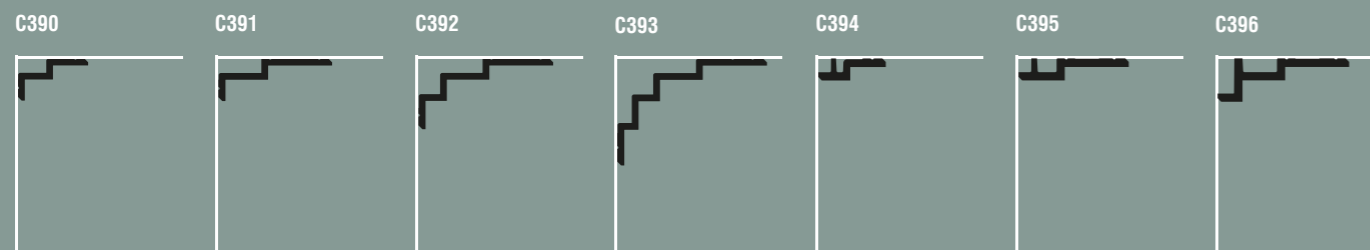

BORDER

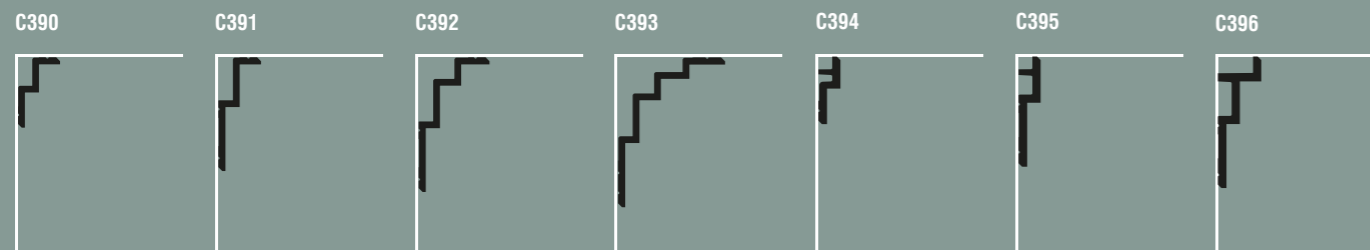

CURTAIN PROFILES | КАРНИЗЫ ДЛЯ ШТОР | PROFILE KARNISZOWE | سلك الستائر | PROFILS RIDEAU

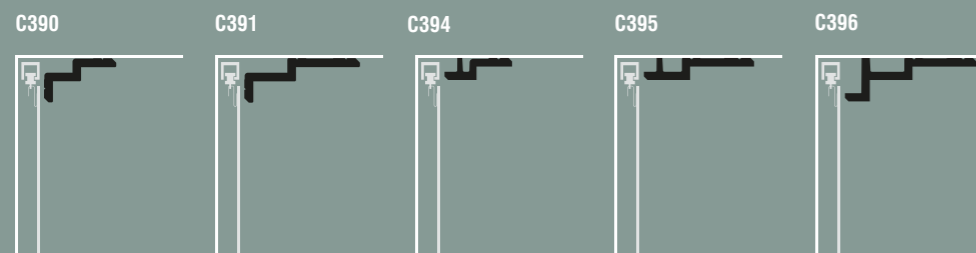

INDIRECT LIGHTING | СКРЫТОЕ ОСВЕЩЕНИЕ | LISTWY OŚWIETLENIOWE | إضاءة غير مباشرة | ÉCLAIRAGE INDIRECT

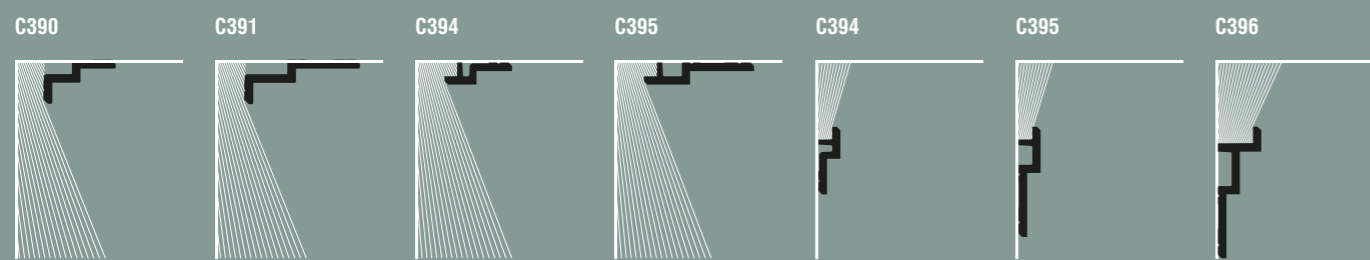

DOWNLIGHTER

UPLIGHTER

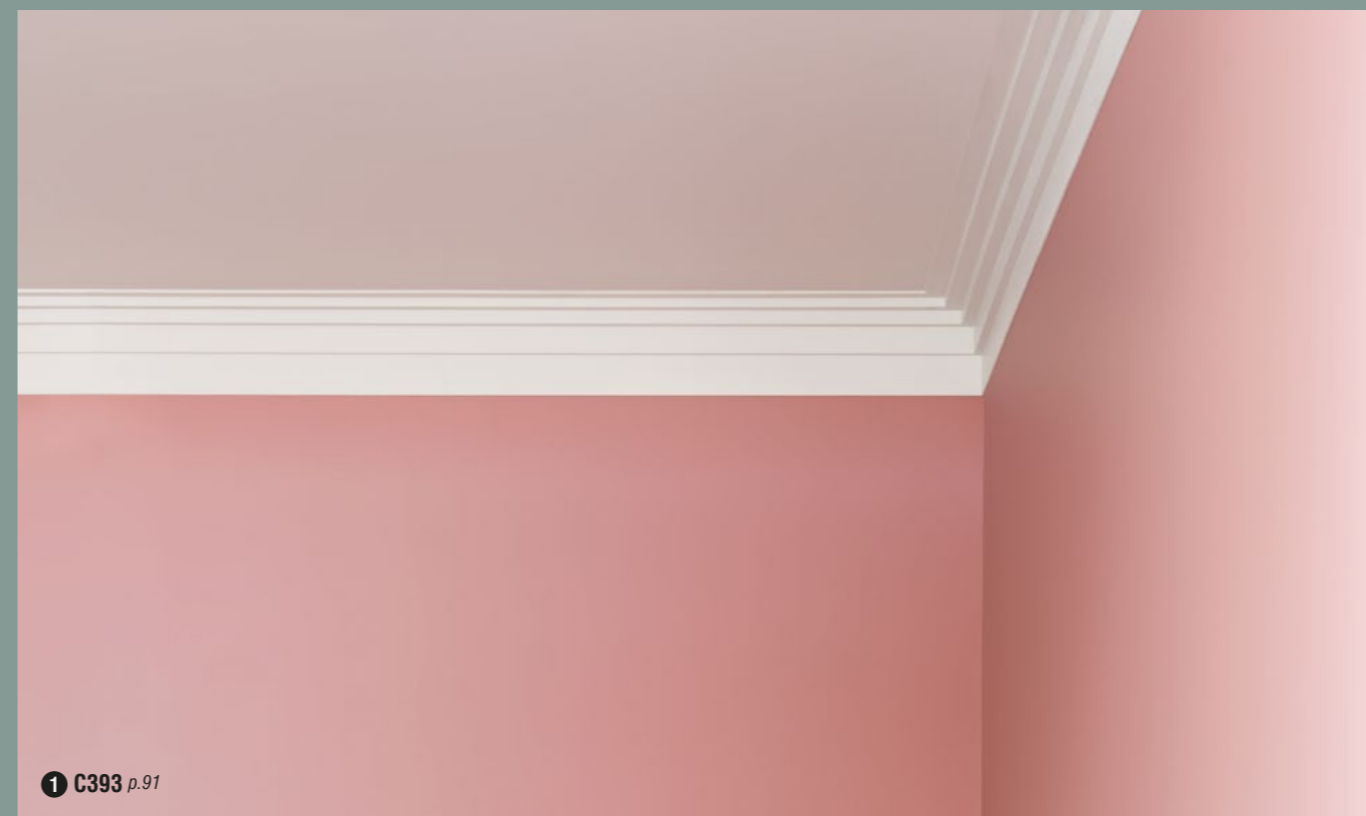

1 C393 p.91

CORNICE MOULDINGS / КАРНИЗЫ / GZYMSY / كرائيش / CORNICHES

CORNICE MOULDINGS / КАРНИЗЫ / GZYMSY / كرائيش / CORNICHES



SX162 | SX162F SQUARE
200 x 1 x 4 cm
Duropolymer®



CX160
200 x 1,3 x 3,9 cm
Duropolymer®



SX182 | SX182F CASCADE
200 x 1,3 x 5 cm
Duropolymer®



SX157 | SX157F SQUARE
200 x 1,3 x 6,6 cm
Duropolymer®



CX161
200 x 1,3 x 6,9 cm
Duropolymer®



SX183 | SX183F CASCADE
200 x 1,3 x 7,5 cm
Duropolymer®





SX163 | SX163F SQUARE
200 x 1,3 x 10,2 cm
Duropolymer®



SX184 | SX184F CASCADE
200 x 1,3 x 11 cm
Duropolymer®

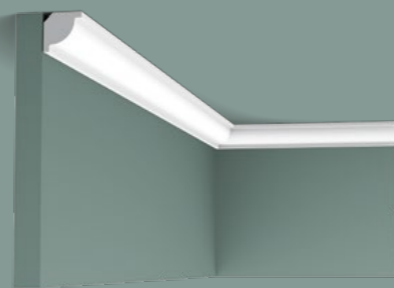

CX132 | CX132F
200 x 2 x 2 cm
Duropolymer®

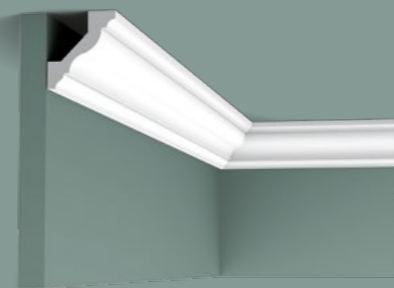
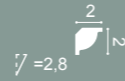

CX110 | CX110F
200 x 4,5 x 4,1 cm
Duropolymer®

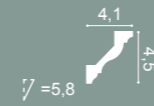

CX124 | CX124F
200 x 4,9 x 4,9 cm
Duropolymer®

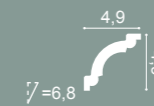

CX108
200 x 5,4 x 5,5 cm
Duropolymer®



CX133
200 x 2 x 2 cm
Duropolymer®

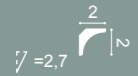

CX190 | CX190F U-PROFILE
200 x 3 x 2 cm
Duropolymer®
Designed by
Orio Tonini

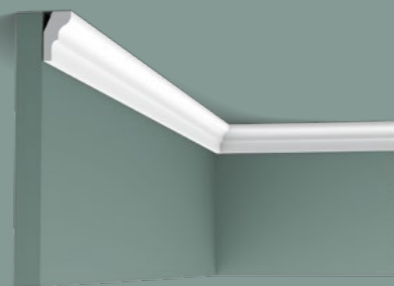

CX111
200 x 2,6 x 1,5 cm
Duropolymer®

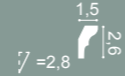

CX112
200 x 5,4 x 3,8 cm
Duropolymer®

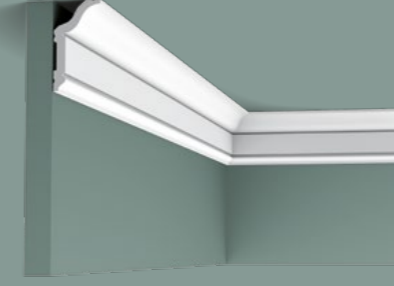
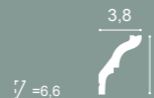

CX141
200 x 5,9 x 3,1 cm
Duropolymer®

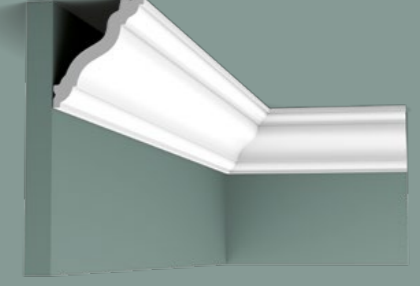
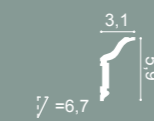

CX177
200 x 7 x 6 cm
Duropolymer®

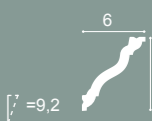

CX154
200 x 3 x 3 cm
Duropolymer®

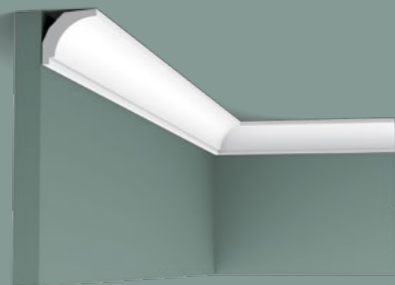

CX115
200 x 3 x 2,9 cm
Duropolymer®

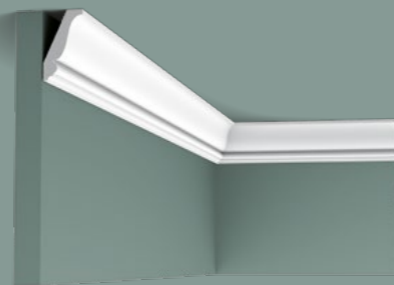
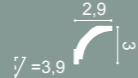

CX151
200 x 4 x 2,3 cm
Duropolymer®



CX176
200 x 8 x 4 cm
Duropolymer®



CX100 | CX100F
200 x 6,9 x 7,1 cm
Duropolymer®

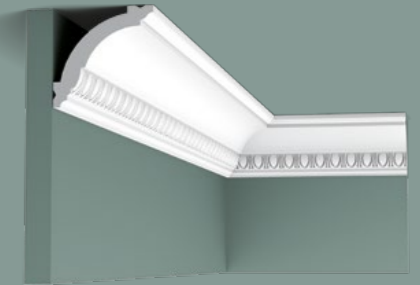

CX101
200 x 6,9 x 7,1 cm
Duropolymer®



CX148 | CX148F
200 x 4,3 x 2,9 cm
Duropolymer®

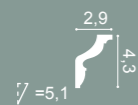

CX150
200 x 4,3 x 2,9 cm
Duropolymer®



CX109 | CX109F
200 x 4,4 x 4,4 cm
Duropolymer®



CX136
200 x 6,9 x 7,1 cm
Duropolymer®

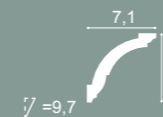

CX123 | CX123F
200 x 8 x 8 cm
Duropolymer®



CX126
200 x 8,7 x 8,7 cm
Duropolymer®





CX127 | CX127F
200 x 9,4 x 9,4 cm
Duropolymer®

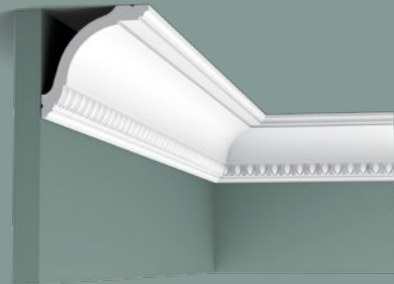
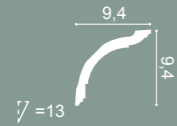

CX128
200 x 9,4 x 9,4 cm
Duropolymer®

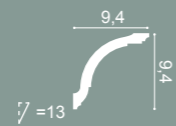

CX129
200 x 9,4 x 9,4 cm
Duropolymer®

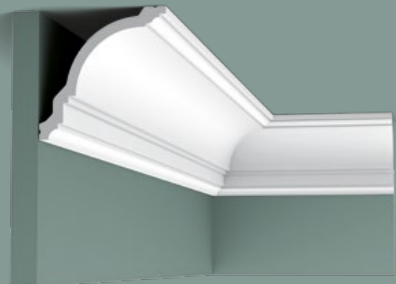
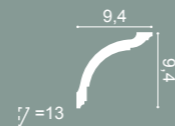

CX106 | CX106F
200 x 11,8 x 11,7 cm
Duropolymer®

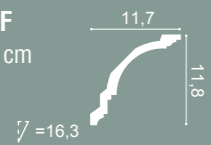

CX107
200 x 11,8 x 11,7 cm
Duropolymer®

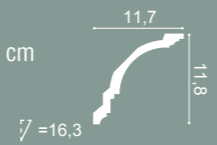

CX192
200 x 12 x 6 cm
Duropolymer®



PX164
200 x 3 x 2,4 cm
Duropolymer®



PB513
200 x 1,5 x 3,4 cm
Durofoam®

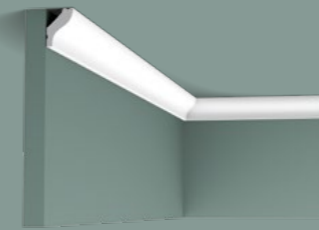

CB500
200 x 2,5 x 1,8 cm
Durofoam®

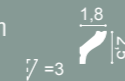

CB530
200 x 2,7 x 1,5 cm
Durofoam®

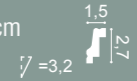

CB520
200 x 3,5 x 3,5 cm
Durofoam®



CB510
200 x 4 x 4 cm
Durofoam®

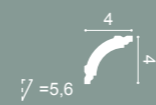

CB501
200 x 4,1 x 3,5 cm
Durofoam®



CB531
200 x 4,8 x 2,6 cm
Durofoam®

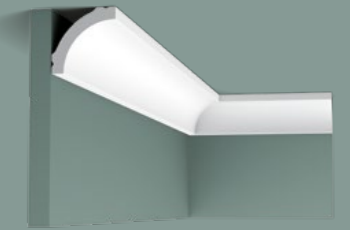
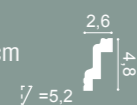

CB521
200 x 5 x 5 cm
Durofoam®

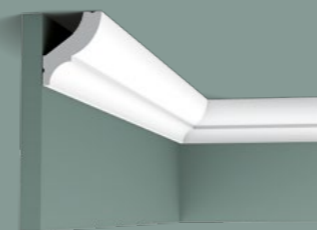

CB502
200 x 5,9 x 4,9 cm
Durofoam®

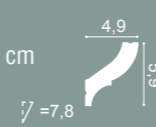

CB523
200 x 5,9 x 4,4 cm
Durofoam®

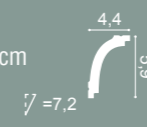

CB525
200 x 6,5 x 6 cm
Durofoam®

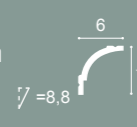

CB511
200 x 6,7 x 6,7 cm
Durofoam®

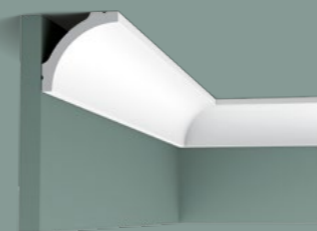
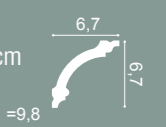

CB522
200 x 6,7 x 6,7 cm
Durofoam®

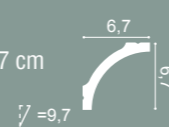

CB503
200 x 8,2 x 9,2 cm
Durofoam®

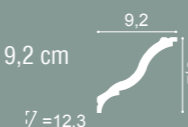

CB524
200 x 9 x 9 cm
Durofoam®

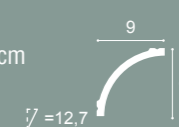

CB512
200 x 9,5 x 10 cm
Durofoam®



Curtain Profiles

КАРНИЗЫ ДЛЯ ШТОР / PROFILE KARNISZOWE
سكك الستائر / PROFILS RIDEAU



C394 STEPS CURTAIN PROFILE
200 x 3,1 x 9,5 cm
Purotouch®
Designed by Orio Tonini

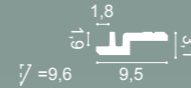

C395 STEPS CURTAIN PROFILE
200 x 3,1 x 15,5 cm
Purotouch®
Designed by Orio Tonini

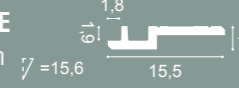

C390 STEPS CURTAIN PROFILE
200 x 6 x 10 cm
Purotouch®
Designed by Orio Tonini



C391 STEPS CURTAIN PROFILE
200 x 6 x 16 cm
Purotouch®
Designed by Orio Tonini

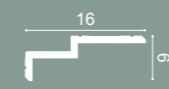

C396 STEPS CURTAIN PROFILE
200 x 6,1 x 18,5 cm
Purotouch®
Designed by Orio Tonini



C341 | C341F HERITAGE CURTAIN PROFILE
200 x 8,8 x 12,2 cm
Purotouch®
Designed by Orio Tonini



C991 CURTAIN PROFILE
200 x 11 x 14 cm
Purotouch®
Designed by Ulf Moritz



C340 CURTAIN PROFILE
200 x 13,5 x 25,6 cm
Purotouch®
Designed by Ulf Moritz

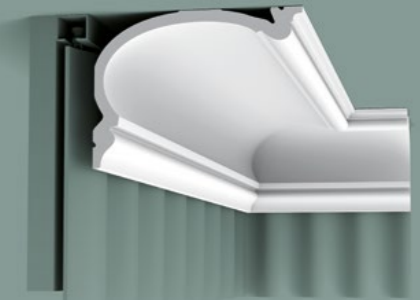

C342 HERITAGE CURTAIN PROFILE
200 x 14 x 19 cm
Purotouch®
Designed by Ulf Moritz



C343 HERITAGE CURTAIN PROFILE
200 x 19 x 25 cm
Purotouch®
Designed by Ulf Moritz



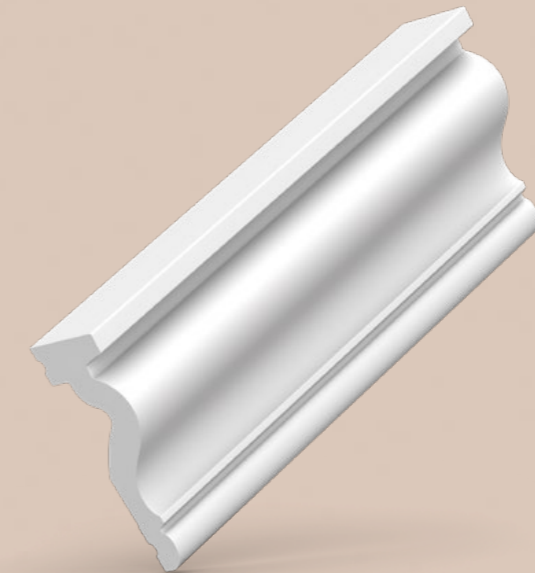

Panel Mouldings

МОЛДИНГИ / PROFILE ŚCIENNE
قوالب للجدران / CIMAISES

en

Make flat walls come to life using "wallscaping" with our extensive panel mould range. Create attractive panelling or frames on walls and ceilings in a jiffy. All designs are easy to install, and many are available in a flexible format for use on curved walls and ceilings.

ru

Оживите плоские стены с помощью широкого ассортимента молдингов. Создайте привлекательные панели или рамки на стенах в один миг. Все дизайны легко устанавливаются. Много моделей доступны также в гибком виде для использования на изогнутых или закругленных стенах или потолках.

pl

Wprowadź życie w swoje płaskie ściany dzięki naszej szerokiej gamie profili ściennych. Stwórz na ścianach i sufitach atrakcyjne boazerie lub ościeżnice w szybki i wygodny sposób. Wszystkie dostępne wzory są łatwe w instalacji, a wiele profili jest dostępnych w wersji elastycznej do stosowania na wygiętych powierzchniach ścian i sufitów.

ar

جعل الجدران العادية تنبض بالحياة هو ما نسميه "wallscaping". بفضل التشكيلة الواسعة من قوالب وألواح الجدران، يمكن خلق تلييسات أو إطارات على الحائط أو السقف في لمح البصر. القوالب سهلة التركيب، وعدد كبير منها متوفر أيضا بصيغة مرنة.

fr

Animer un mur uni, c'est ce que nous appelons le « wallscaping ». Le vaste choix de cimaises permet de créer en un clin d'œil un lambris ou un encadrement sur le mur ou le plafond. Elles sont en outre faciles à poser et bon nombre d'entre elles sont disponibles en version flexible.

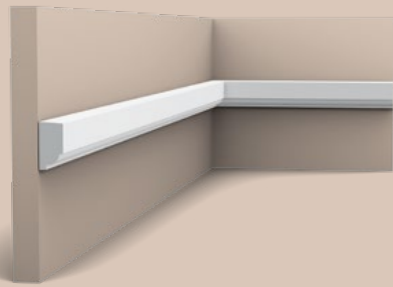

P9050 | P9050F
200 x 2,5 x 1,3 cm
Purotouch®

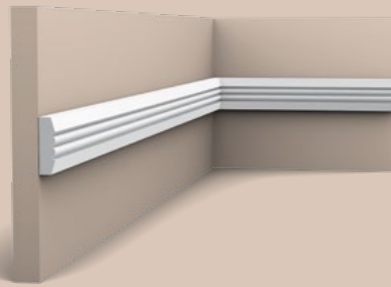

P5021 | P5021F
200 x 3,1 x 0,9 cm
Purotouch®

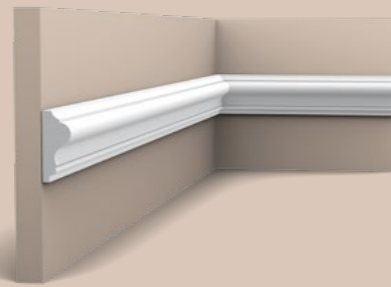

P8030 | P8030F
200 x 4,1 x 1,7 cm
Purotouch®

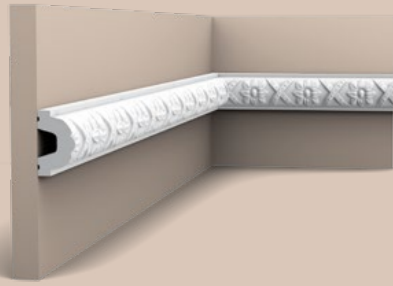

P2020 | P2020F
200 x 4,4 x 2,6 cm
Purotouch®

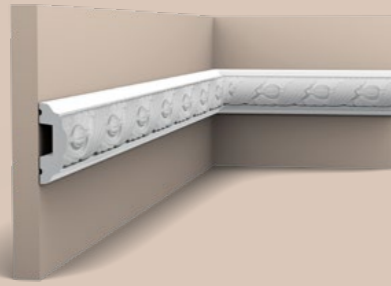

P1020 | P1020F
200 x 4,9 x 2,4 cm
Purotouch®

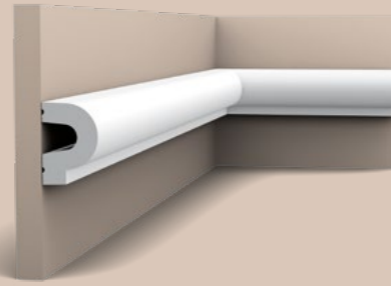

P8060 | P8060F
200 x 5 x 3,5 cm
Purotouch®



3 SX118 p.120

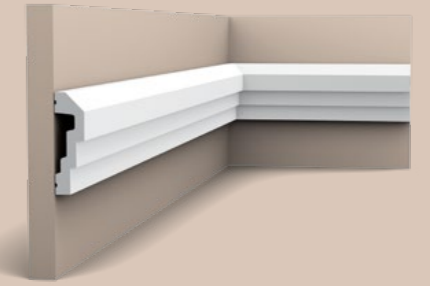

P7070 | P7070F
200 x 7,4 x 2,2 cm
Purotouch®

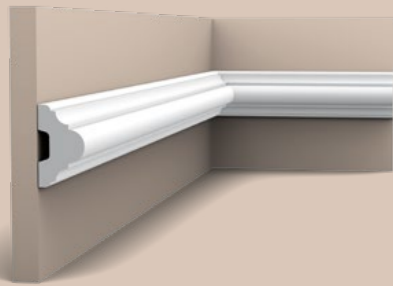

1 P4020 | P4020F
200 x 5 x 2,9 cm
Purotouch®

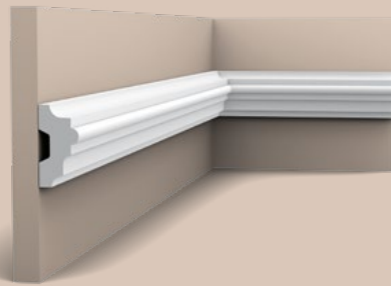

P9040 | P9040F
200 x 5 x 2,5 cm
Purotouch®

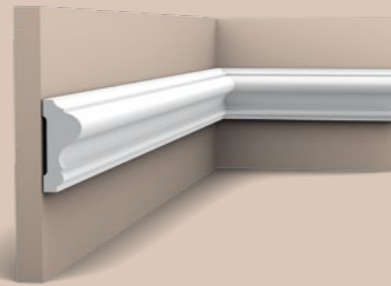

2 P8020 | P8020F
200 x 6 x 2,6 cm
Purotouch®

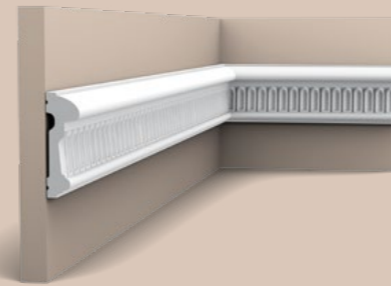

P7040 | P7040F
200 x 7,9 x 2,6 cm
Purotouch®

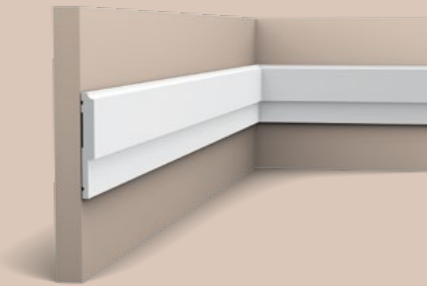

P9900 | P9900F
200 x 8 x 1 cm
Purotouch®

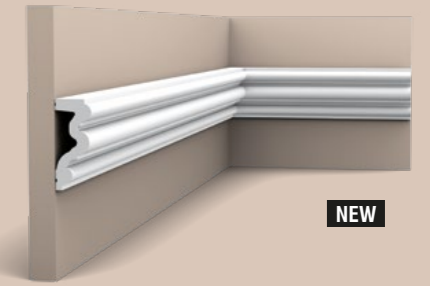

P4025 | P4025F AUTOIRE
200 x 8,3 x 3,4 cm
Purotouch®
Designed by
Orio Tonini



NEW

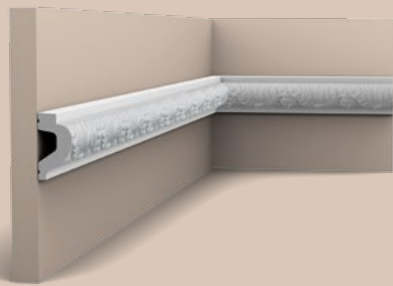

P3020 | P3020F
200 x 6,1 x 3,2 cm
Purotouch®

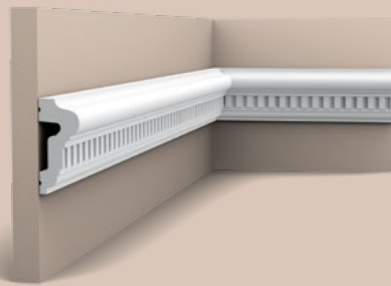

P6020 | P6020F
200 x 6,4 x 2,8 cm
Purotouch®

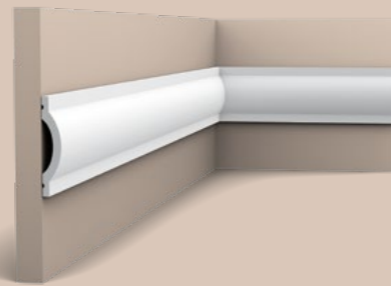

P9901 | P9901F
200 x 7 x 1,4 cm
Purotouch®

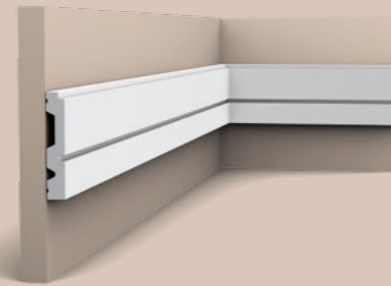

P5051
200 x 8,4 x 1,5 cm
Purotouch®
Designed by
Jacques Vergracht

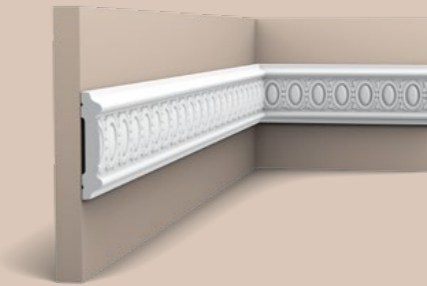

P7030 | P7030F
200 x 8,5 x 1,7 cm
Purotouch®

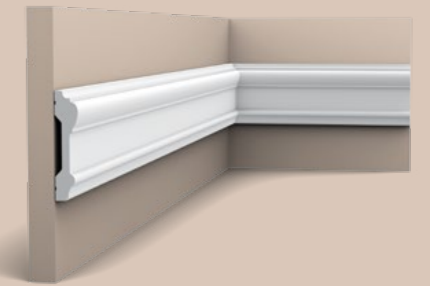

P9010 | P9010F
200 x 9,1 x 3 cm
Purotouch®



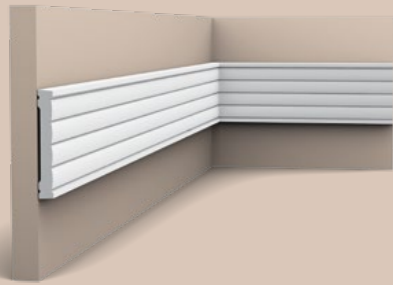

P5020 | P5020F
200 x 9,1 x 1,3 cm
Purotouch®

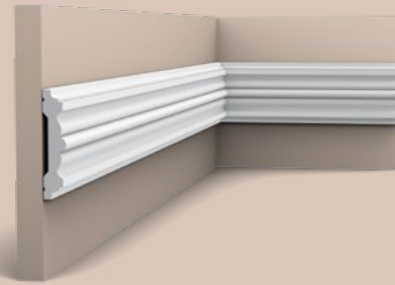

P9020 | P9020F
200 x 9,6 x 2,1 cm
Purotouch®

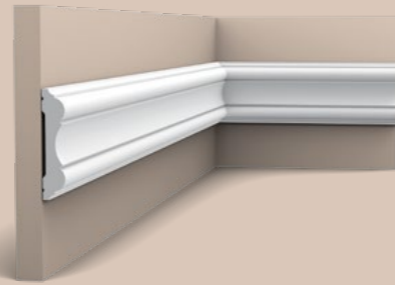

P8040 | P8040F
200 x 10,1 x 2,2 cm
Purotouch®

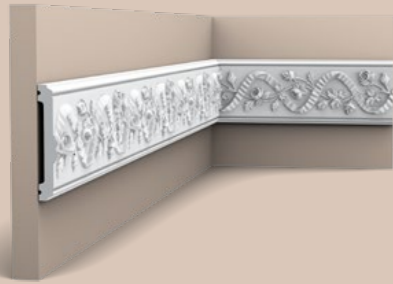

P7010 | P7010F
200 x 10,5 x 2 cm
Purotouch®

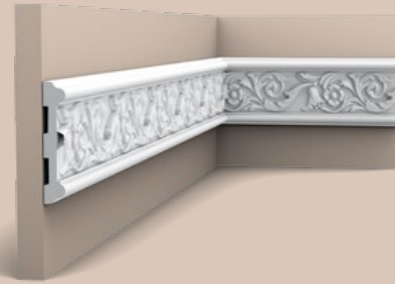

P7020 | P7020F
200 x 11,1 x 1,9 cm
Purotouch®

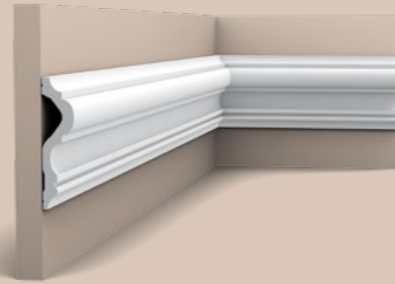

P8050 | P8050F
200 x 12 x 3 cm
Purotouch®

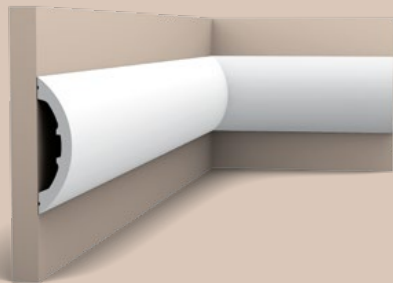

P3070 RADIUS
200 x 12,5 x 3,2 cm
Purotouch®
Designed by
Ulf Moritz

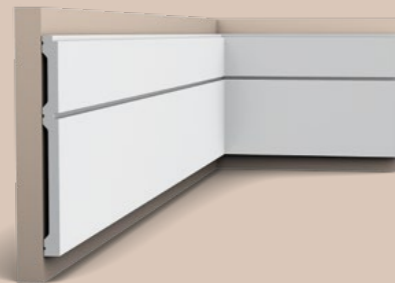

P5050
200 x 20 x 1,5 cm
Purotouch®
Designed by
Jacques Vergracht



P7080
200 x 21,8 x 2,9 cm
Purotouch®

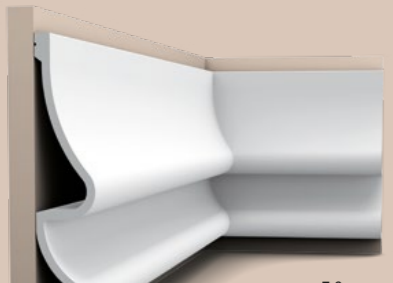

P3071 GOLF
200 x 37,2 x 7,6 cm
Purotouch®
Designed by
Ulf Moritz



- 1 DX170-2300 p.150
- 2 P8020 p.106
- 3 P4020 p.106
- 4 D330LR p.150
- 5 SX118 p.120

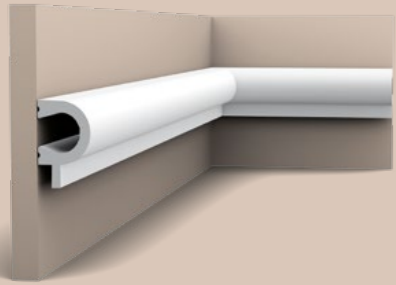

PX169 A
200 x 5,5 x 3,4 cm
Duropolymer®

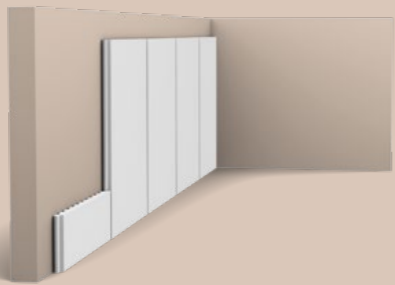

PX147 B
200 x 16,9 x 0,9 cm
Duropolymer®

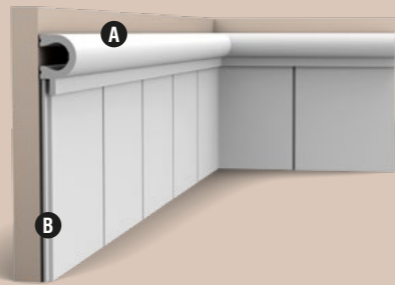

PX169 + PX147

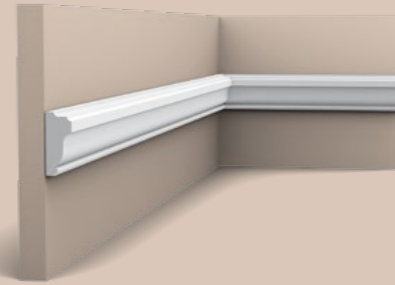

PX117
200 x 3,5 x 1,5 cm
Duropolymer®

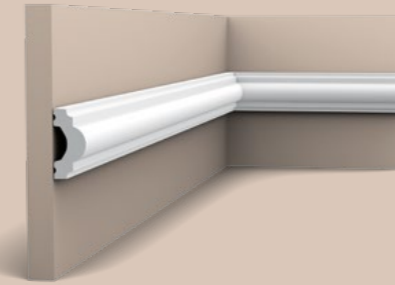

PX120 | PX120F
200 x 4 x 1,9 cm
Duropolymer®

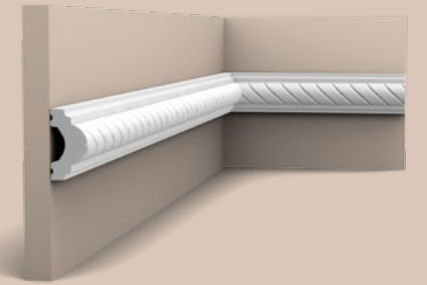

PX131
200 x 4 x 1,9 cm
Duropolymer®

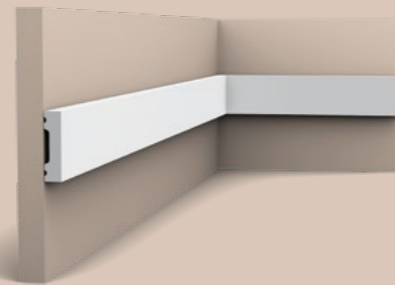

**SX162 | SX162F
SQUARE**
200 x 4 x 1 cm
Duropolymer®

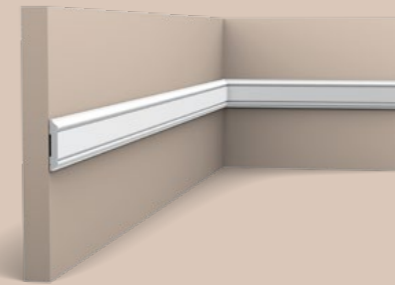

PX144 | PX144F
200 x 4,7 x 0,8 cm
Duropolymer®

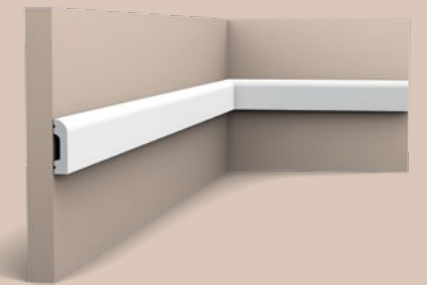

**SX182 | SX182F
CASCADE**
200 x 5 x 1,3 cm
Duropolymer®

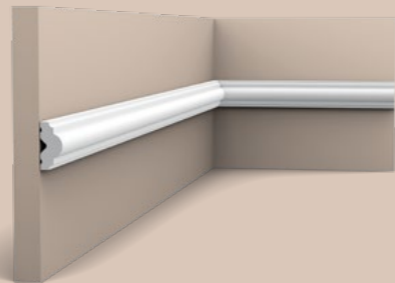

PX103 | PX103F
200 x 2,5 x 1,2 cm
Duropolymer®

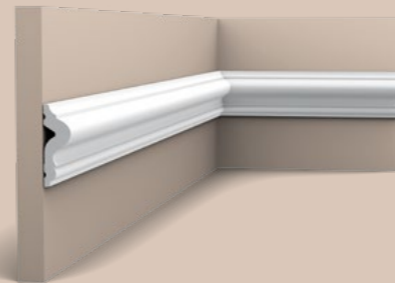

PX175 | PX175F
200 x 5 x 1,7 cm
Duropolymer®

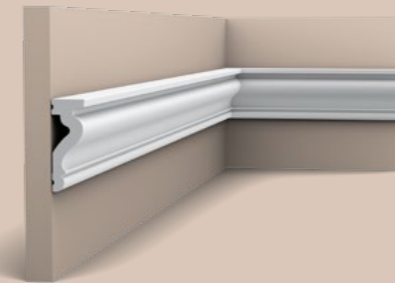

DX174-2300 | DX174F
230 x 6 x 2,2 cm (DX174-2300)
Duropolymer®
200 x 6 x 2,2 cm (DX174F)

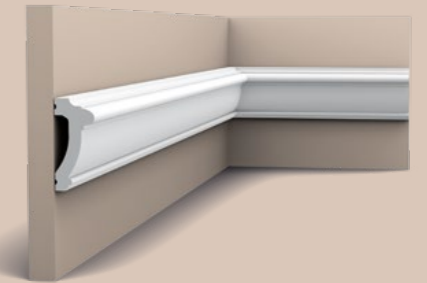

PX113
200 x 6 x 2,7 cm
Duropolymer®

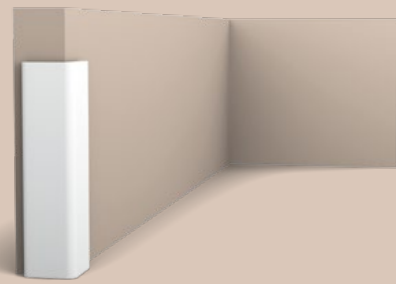

CX134
200 x 3 x 3 cm
Duropolymer®

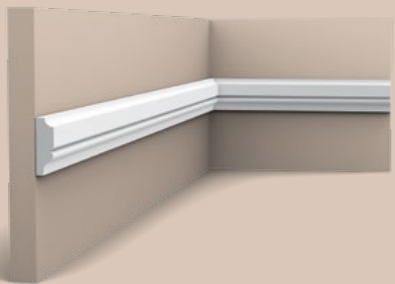

PX116
200 x 3,1 x 1 cm
Duropolymer®

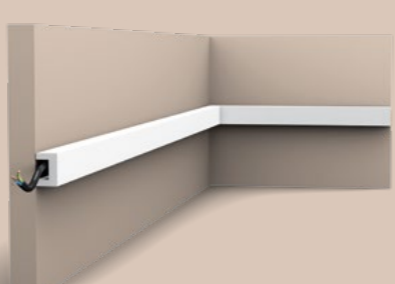

CX190 | CX190F U-PROFILE
200 x 3 x 2 cm
Duropolymer®
Designed by
Orio Tonini

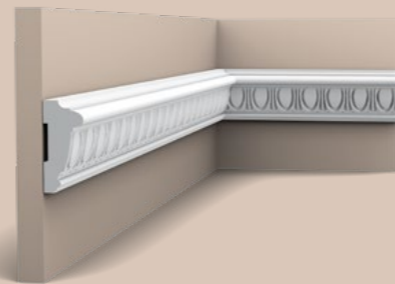

PX114
200 x 6 x 2,7 cm
Duropolymer®

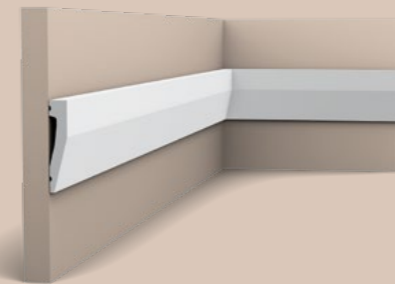

SX159
200 x 6 x 1,2 cm
Duropolymer®

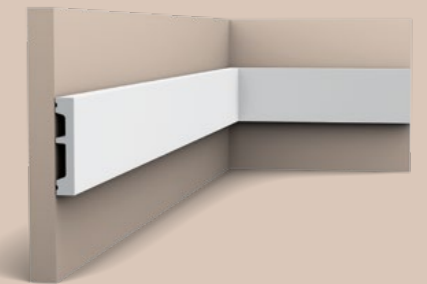

**SX157 | SX157F
SQUARE**
200 x 6,6 x 1,3 cm
Duropolymer®



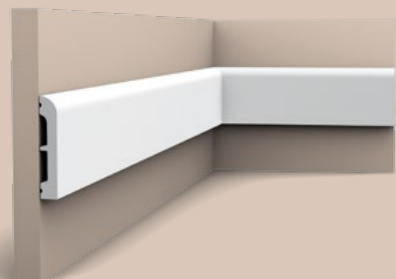

**SX183 | SX183F
CASCADE**
200 x 7,5 x 1,3 cm
Duropolymer®

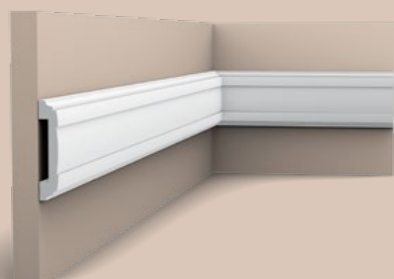

PX102
200 x 7,9 x 1,6 cm
Duropolymer®

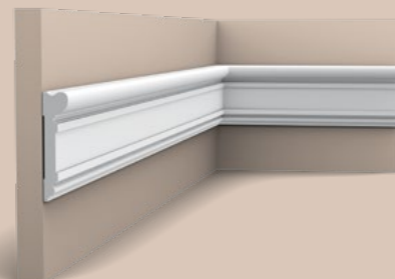

DX119-2300
230 x 9,2 x 2,2 cm
Duropolymer®

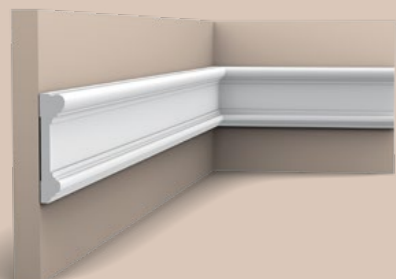

DX121-2300
230 x 9,4 x 2,3 cm
Duropolymer®

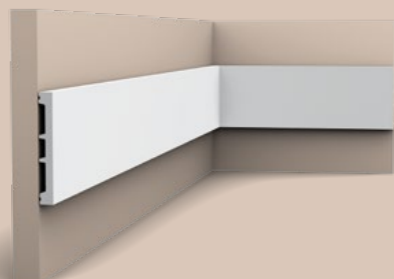

**SX163 | SX163F
SQUARE**
200 x 10,2 x 1,3 cm
Duropolymer®

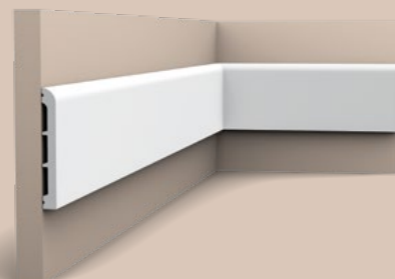

**SX184 | SX184F
CASCADE**
200 x 11 x 1,3 cm
Duropolymer®

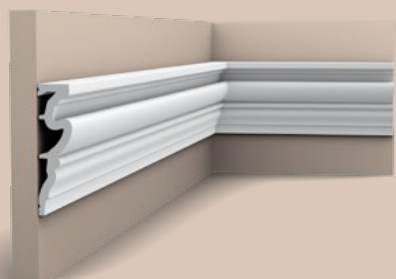

DX170-2300
230 x 11,9 x 3,2 cm
Duropolymer®

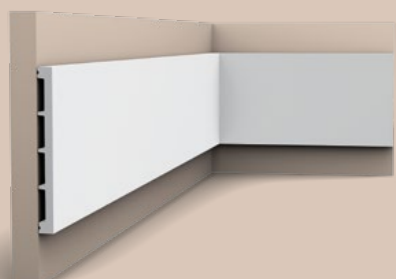

**SX168
SQUARE**
200 x 15,1 x 1,4 cm
Duropolymer®



- 1 P3020 p.106
- 2 P8020 p.106
- 3 P3020A

- 4 P8050 p.108
- 5 SX118 p.120
- 6 P8040 p.108



P5020B + P5020
9 x 9 x 1,3 cm
Purotouch®



P101A + P1020
24,5 x 24,5 x 2,4 cm
Purotouch®



P201A + P2020 + P21
19,5 x 19,5 x 2,6 cm
Purotouch®



P801C + P8020
19,8 x 11 x 2,6 cm
Purotouch®



P4020A + P4020
16,4 x 9,1 x 2,9 cm
Purotouch®



P3020A + P3020
42,5 x 42,5 x 4 cm
Purotouch®



P20 + P101A
Ø 6,1 - 0,8 cm
Duropolymer®



P21 + P201A
6,7 x 6,7 x 0,9 cm
Duropolymer®



PX103A + PX103
19 x 3,5 x 1,2 cm
Duropolymer®



P8030D + P8030
13,2 x 13,2 x 1,7 cm
Duropolymer®



P8030C + P8030
19 x 8,6 x 1,7 cm
Duropolymer®



PX120A + PX120
19 x 8,8 x 2 cm
Duropolymer®

Skirting

ПЛИНТУСЫ / LISTWY PRZYPODŁOGOWE
نعلات / PLINTHES



en

All skirting boards are made from Duropolymer®, an impact- and water-resistant polymer mix that is fully recyclable. Cables can be hidden easily, and the flexible versions allow curved walls to be finished elegantly. The skirting boards are pre-primed for easy painting.

ru

Все плинтусы сделаны из материала дурополимер (Duropolymer®) – ударопрочного и водостойкого полимера. Скрывает проводку. Любая изогнутая или закругленная стена может быть красиво отделана гибкими моделями. Плинтусы имеют прогрунтованную поверхность для легкости окрашивания.

pl

Wszystkie listwy przypodłogowe są wykonane z duropolimeru – mieszaniny polimerów odpornej na uderzenia i zamoczenia, w całości nadającej się do recyklingu. Wszelkiego rodzaju kable i przewody mogą być z łatwością ukryte pod listwami, a elastyczne wersje pozwalają na eleganckie wykończenie zakrzywionych powierzchni ścian. Dzięki wstępnemu gruntowaniu listwy są łatwe do malowania.

ar

جميع النعلات مصنوعة من دوروبوليمر®، مزيج بوليمرات مقاوم للحماء والصدمات وقابل لإعادة التدوير بالكامل. يمكن إخفاء الكابلات بسهولة، ويمكن إستعمال القوالب المرنة لتزيين الجدران المقوسة بشكل أنيق. النعلات مدهونة مسبقاً بأساس لتسهيل عملية الطلاء.

fr

Toutes les plinthes sont en Duropolymer®, un mélange polymère résistant à l'eau et aux impacts qui est 100 % recyclable. Elles permettent d'aisément dissimuler les câbles, et les variantes flexibles sont idéales pour une finition élégante de murs cintrés. Par ailleurs, les plinthes sont livrées avec une couche de peinture primaire et peuvent facilement être mises en peinture.

3 SKIRTING FAMILIES

CHOOSE YOUR STYLE. GET CREATIVE.

ru

3 семейства плинтусов.
Выберите свой стиль.
Вдохновляйтесь и
создавайте.

pl

3 rodziny listew.
Wybierz swój styl. Bądź
kreatywny.

ar

ثلاث مجموعات من النعلات.
اختراروا نمطكم. كونوا مبدعين.

fr

3 familles de
plinthes.
Choisissez votre style.
Faites preuve de créativité.

SQUARE



CASCADE



CONTOUR



SMALL

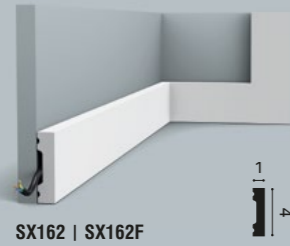

SX162 | SX162F

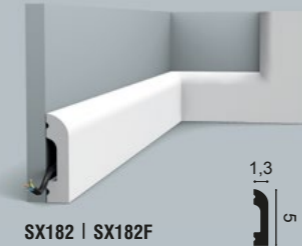

SX182 | SX182F

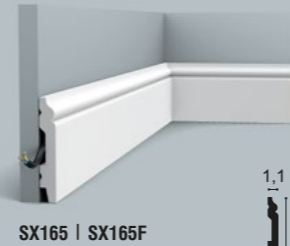

SX165 | SX165F



MEDIUM

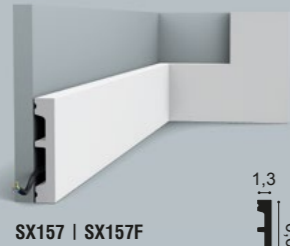

SX157 | SX157F

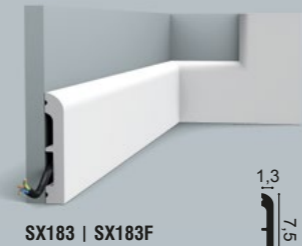

SX183 | SX183F

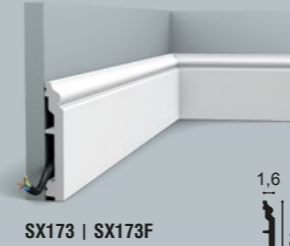

SX173 | SX173F



BIG

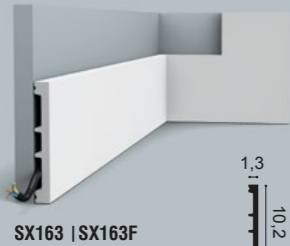

SX163 | SX163F

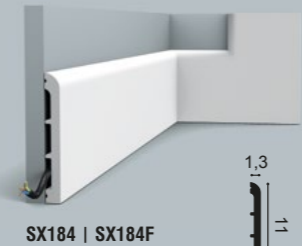

SX184 | SX184F

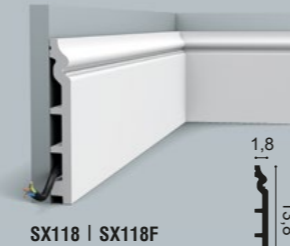

SX118 | SX118F



COVER

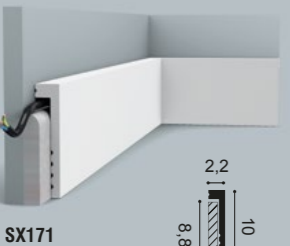

SX171

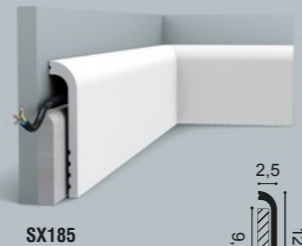

SX185

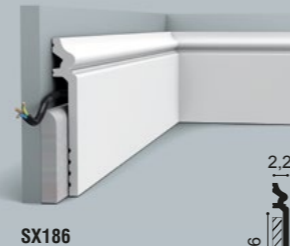
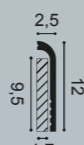

SX186



ADVANTAGES

ПРЕИМУЩЕСТВА / ZALETY / المميزات / VENTAJAS

PAINTABLE

Легко окрашиваются | Można
malować | يمكن طلاؤها
Peut être peint



WATER RESISTANT

Не боятся воды | Wodoodporne
مقاومة للماء | Résistant à l'eau



SHOCK RESISTANT

Ударопрочные | Odporne na wstrząsy
مقاومة للصدمات | Résistant aux chocs

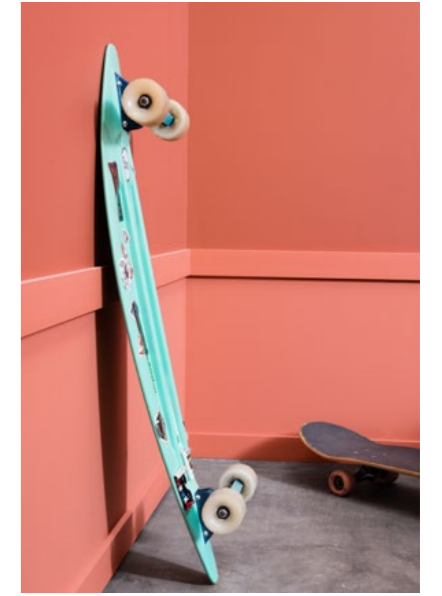

FLEXIBLE

Гибкие | Elastyczne
مرنة | Flexible



MULTIFUNCTIONAL

Многофункциональные
Wielofunkcyjne | متعددة الإستعمالات
Multifonctionnel



COVER SKIRTING

Накладной плинтус
Listwa przykrywająca | نعلة تغطية
Surplinthe



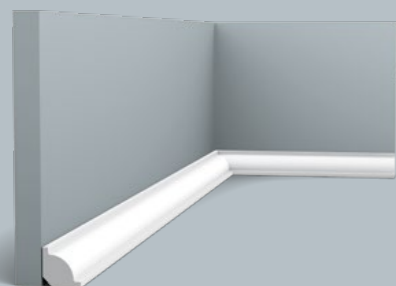

CX132 | CX132F
200 x 2 x 2 cm
Duropolymer®

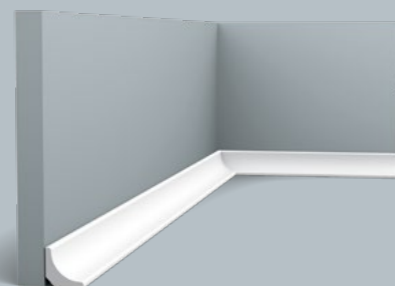

CX133
200 x 2 x 2 cm
Duropolymer®

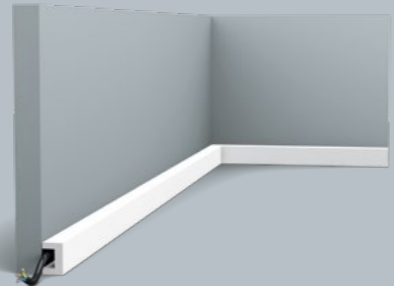

CX190 | CX190F U-PROFILE
200 x 3 x 2 cm
Duropolymer®
Designed by
Orio Tonini

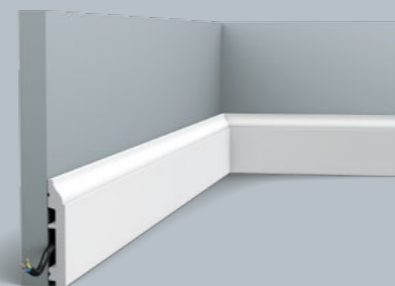

SX172 | SX172F
200 x 8,5 x 1,4 cm
Duropolymer®

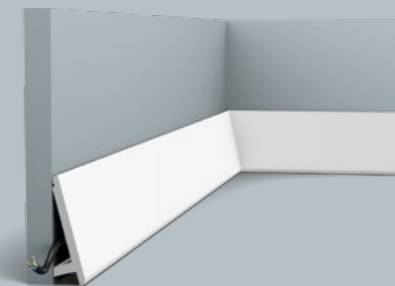

SX179 | SX179F DIAGONAL
200 x 9,7 x 2,9 cm
Duropolymer®
Designed by
Orio Tonini

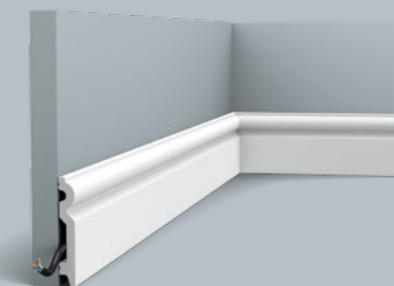
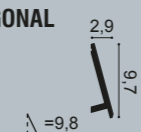

SX137 | SX137F
200 x 9,9 x 1,5 cm
Duropolymer®

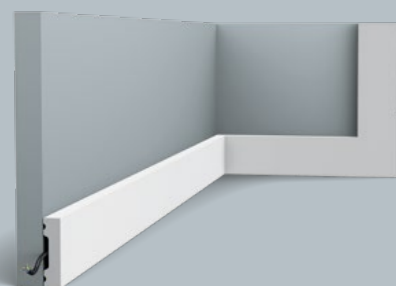

SX162 | SX162F SQUARE
200 x 4 x 1 cm
Duropolymer®

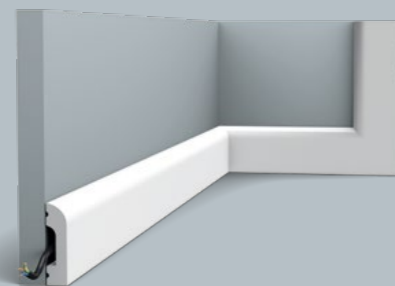

SX182 | SX182F CASCADE
200 x 5 x 1,3 cm
Duropolymer®

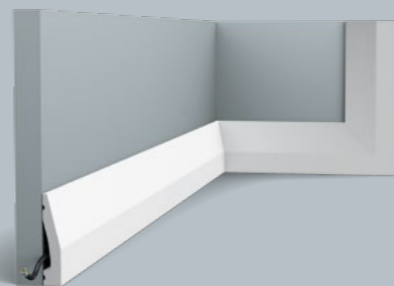

SX159
200 x 6 x 1,2 cm
Duropolymer®

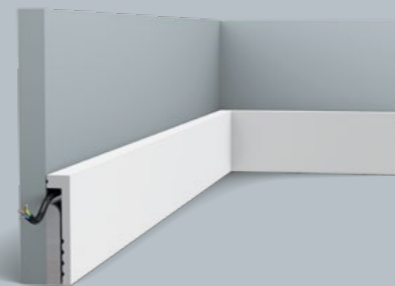

SX171 SQUARE
200 x 10 x 2,2 cm
Duropolymer®

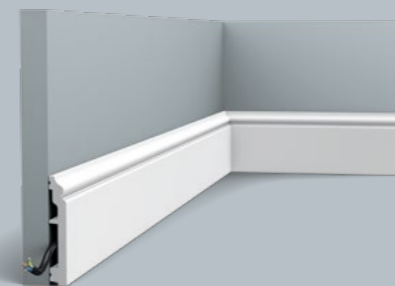

SX173 | SX173F CONTOUR
200 x 10 x 1,6 cm
Duropolymer®

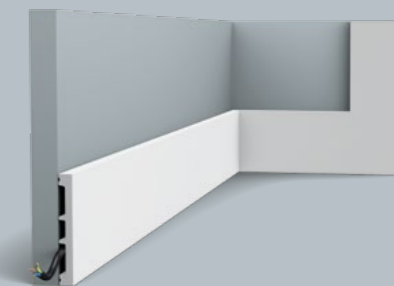
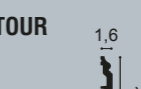

SX163 | SX163F SQUARE
200 x 10,2 x 1,3 cm
Duropolymer®

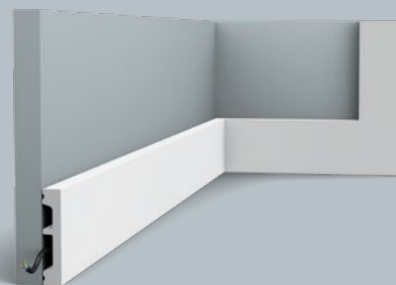

SX157 | SX157F SQUARE
200 x 6,6 x 1,3 cm
Duropolymer®

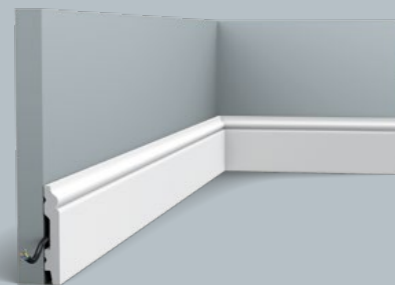

SX165 | SX165F CONTOUR
200 x 6,9 x 1,1 cm
Duropolymer®

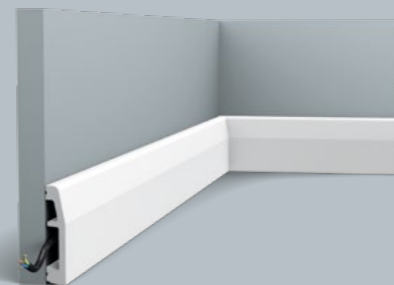

SX125
200 x 6,9 x 1,4 cm
Duropolymer®

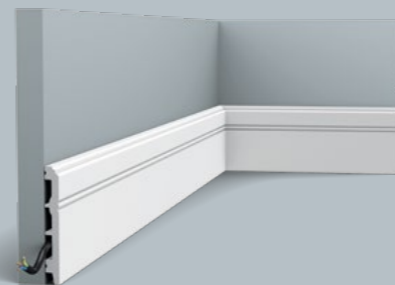

SX105 | SX105F
200 x 10,8 x 1,3 cm
Duropolymer®

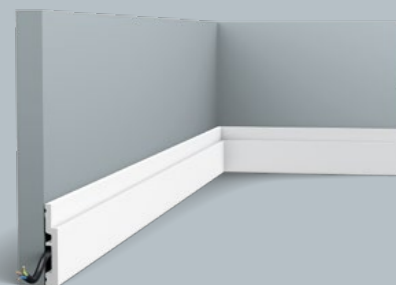

SX187 | SX187F HIGH LINE
200 x 7,5 x 1,2 cm
Duropolymer®
Designed by
Pierre Daems

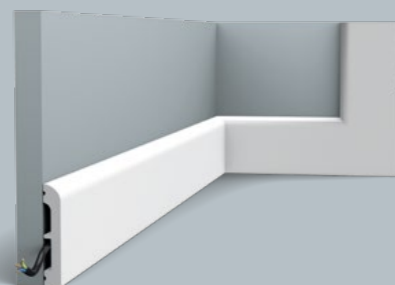

SX183 | SX183F CASCADE
200 x 7,5 x 1,3 cm
Duropolymer®

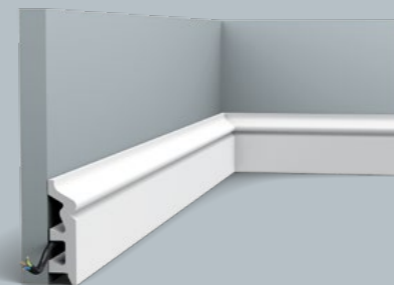

SX122
200 x 7,9 x 2,2 cm
Duropolymer®

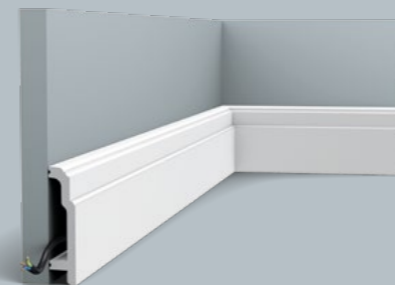

SX155 | SX155F
200 x 10,8 x 2,5 cm
Duropolymer®



- 1 P8020 p. 106
- 2 P8050 p. 108
- 3 SX118 p. 120

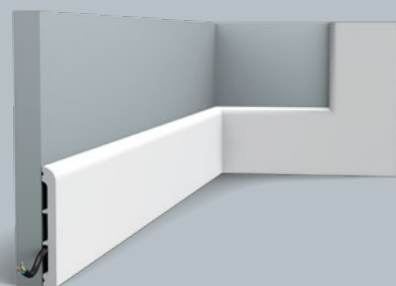

SX184 | SX184F CASCADE
200 x 11 x 1,3 cm
Duropolymer®

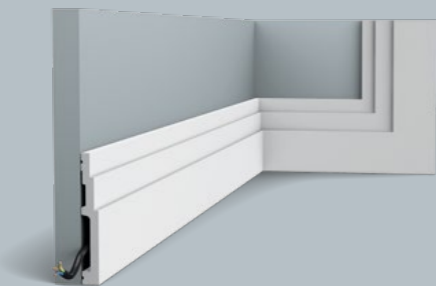

1 SX180 | SX180F HIGH LINE
200 x 12 x 1,6 cm
Duropolymer®
Designed by
Pierre Daems

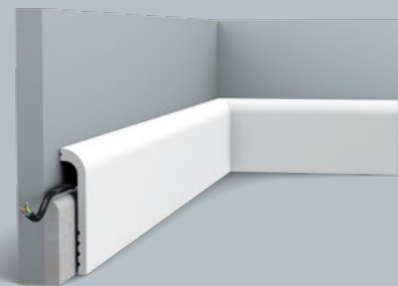
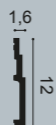

SX185 CASCADE
200 x 12 x 2,5 cm
Duropolymer®

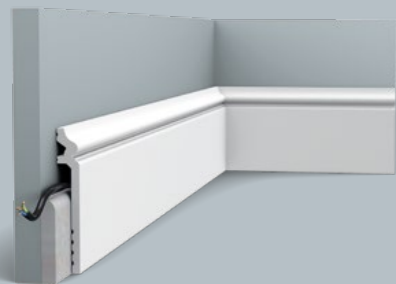
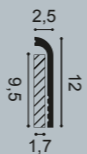

SX186 CONTOUR
200 x 13,8 x 2,2 cm
Duropolymer®

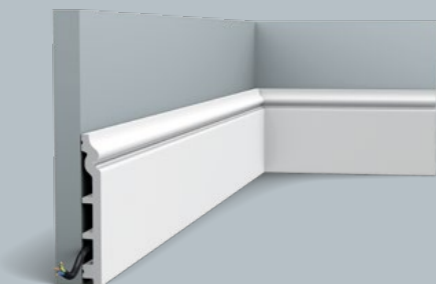
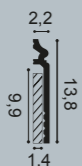

SX118 | SX118F CONTOUR
200 x 13,8 x 1,8 cm
Duropolymer®

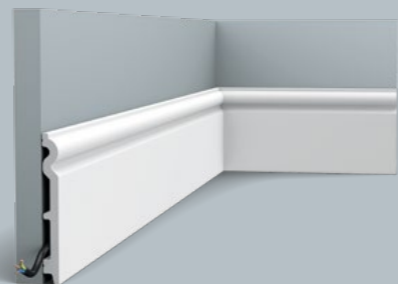

SX138 | SX138F
200 x 13,8 x 1,5 cm
Duropolymer®

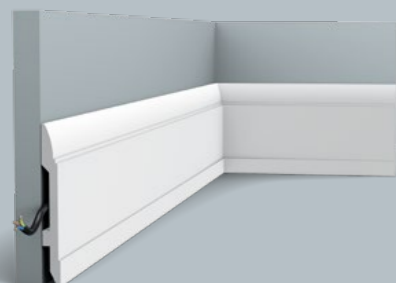

SX104 | SX104F
200 x 14,8 x 1,7 cm
Duropolymer®

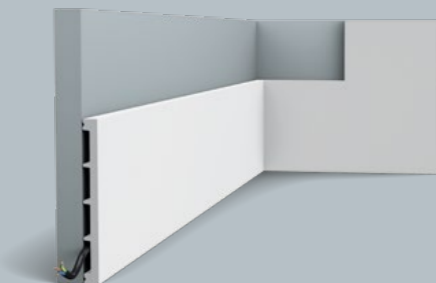

SX168 SQUARE
200 x 15,1 x 1,4 cm
Duropolymer®

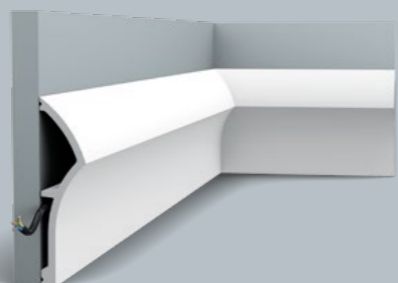
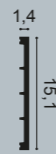

SX167 DUNE
200 x 17,3 x 4,3 cm
Duropolymer®
Designed by Ulf Moritz

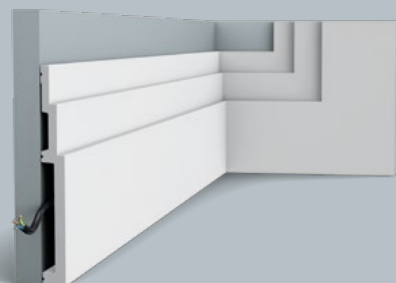

SX181 HIGH LINE
200 x 20 x 2,2 cm
Duropolymer®
Designed by
Pierre Daems

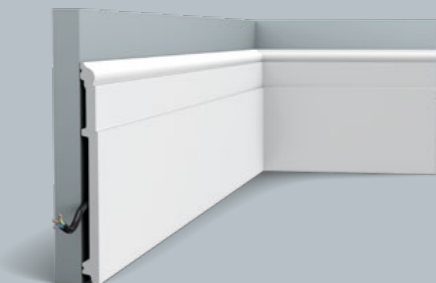

SX156 HIGH HEELS
200 x 20,2 x 1,6 cm
Duropolymer®
Designed by
Xavier Donck



3 SX191 HIGH RISE
200 x 21 x 2,1 cm
Duropolymer®

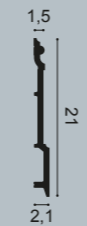

NEW



1 DX170-2300 p.112

2 P8020 p.106

Cover Skirting

НАКЛАДНОЙ ПЛИНТУС / LISTWA PRZYKRYWAJĄCA
نعلة تغطية / SURPLINTHE

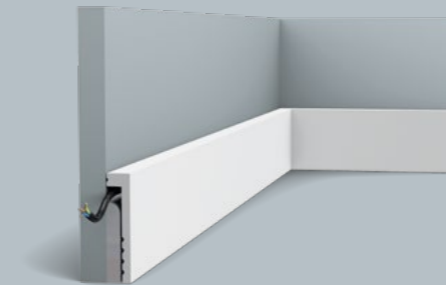

SX171 SQUARE
200 x 10 x 2,2 cm
Duropolymer[®]

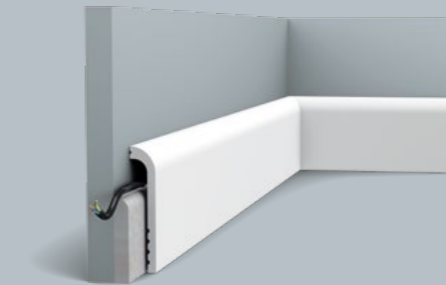
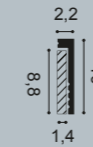

SX185 CASCADE
200 x 12 x 2,5 cm
Duropolymer[®]

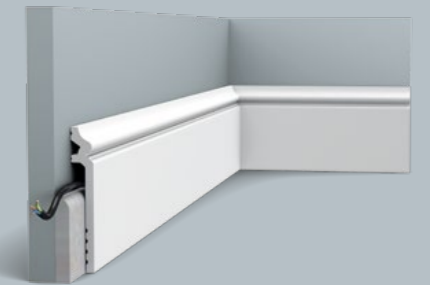

SX186 CONTOUR
200 x 13,8 x 2,2 cm
Duropolymer[®]

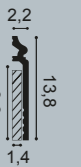

PAINTABLE
Легко окрашиваются
Można malować
يمكن طلاؤها
Peut être peint

WATER RESISTANT
Не боятся воды
Wodoodporne
مقاومة للماء
Résistant à l'eau

IDEAL FOR RENOVATIONS
Идеален для ремонта
Idealne do renowacji
مثالية لأعمال الترميم
Idéal pour des rénovations



1

1 SX118 p.120

3 PX175 p.111

Multifunctional

МНОГОФУНКЦИОНАЛЬНЫЕ / WIELOFUNKCYJNE

متعددة الإستعمالات / MULTIFONCTIONNEL

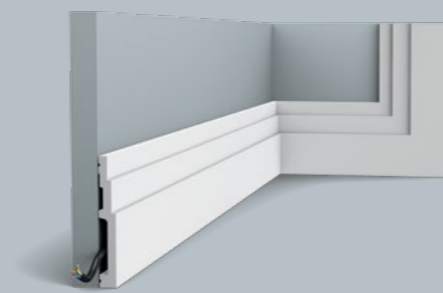

SX180 | SX180F HIGH LINE
200 x 12 x 1,6 cm
Duropolymer®
Designed by
Pierre Daems

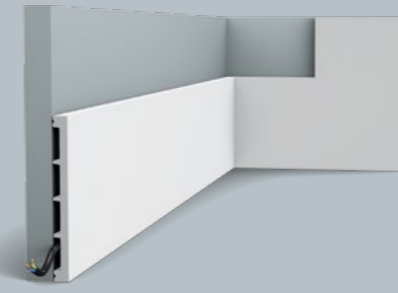

SX168 SQUARE
200 x 15,1 x 1,4 cm
Duropolymer®

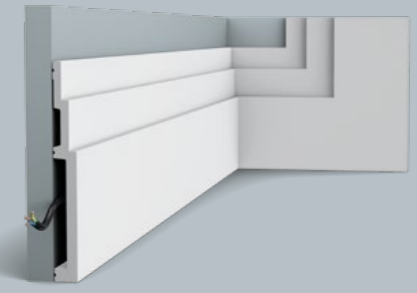

SX181 HIGH LINE
200 x 20 x 2,2 cm
Duropolymer®
Designed by
Pierre Daems

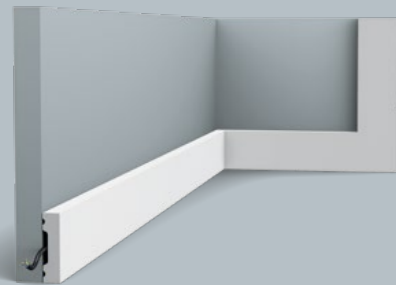

SX162 | SX162F SQUARE
200 x 4 x 1 cm
Duropolymer®

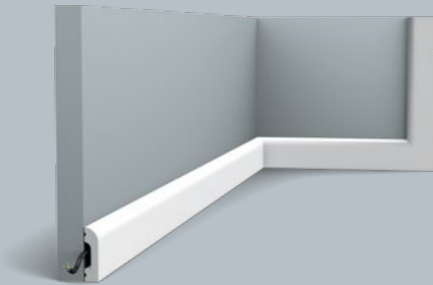

SX182 | SX182F CASCADE
200 x 5 x 1,3 cm
Duropolymer®

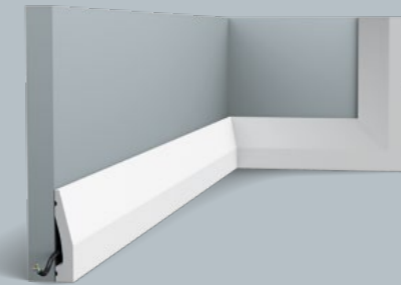

SX159
200 x 6 x 1,2 cm
Duropolymer®

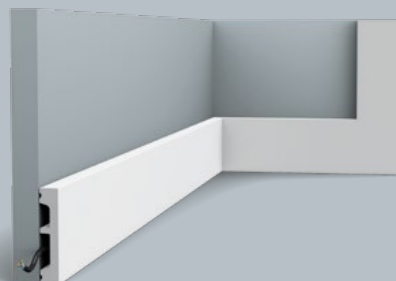

SX157 | SX157F SQUARE
200 x 6,6 x 1,3 cm
Duropolymer®

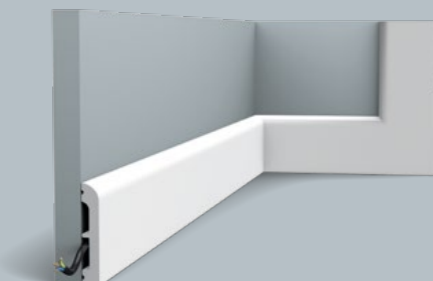

SX183 | SX183F CASCADE
200 x 7,5 x 1,3 cm
Duropolymer®

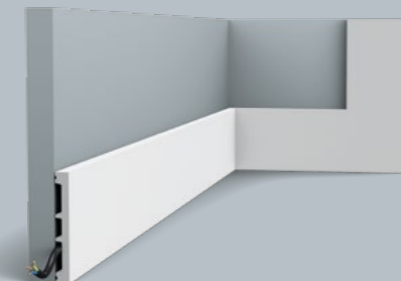

SX163 | SX163F SQUARE
200 x 10,2 x 1,3 cm
Duropolymer®

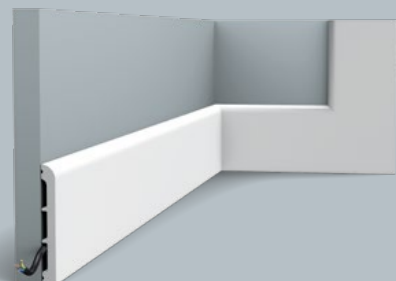
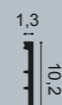

SX184 | SX184F CASCADE
200 x 11 x 1,3 cm
Duropolymer®



en

Profiles with endless possibilities. Each element can be used as a panel moulding, cornice moulding, door surround or as skirting board.

ru

Бесконечное множество вариантов использования. Один и тот же профиль можно использовать как молдинг, карниз, дверное обрамление или плинтус.

pl

Profil z nieskończonymi możliwościami. Jeden i ten sam element może być użyty jako sztukateria, listwa przysufitowa, obramowanie drzwi czy listwa przypodłogowa.

ar

قوالب ذات إستعمالات غير محدودة. يمكن استعمال القالب نفسه ككورنيش، إطار للأبواب، قالب للجدران ونعلة.

fr

Des profils avec des possibilités illimitées. Un même profil peut être utilisé comme décoration murale: comme encadrement de porte, corniche, cimaise ou comme plinthe.



Indirect Lighting

СКРЫТОЕ ОСВЕЩЕНИЕ / LISTWY OŚWIETLENIOWE
إضاءة غير مباشرة / ÉCLAIRAGE INDIRECT

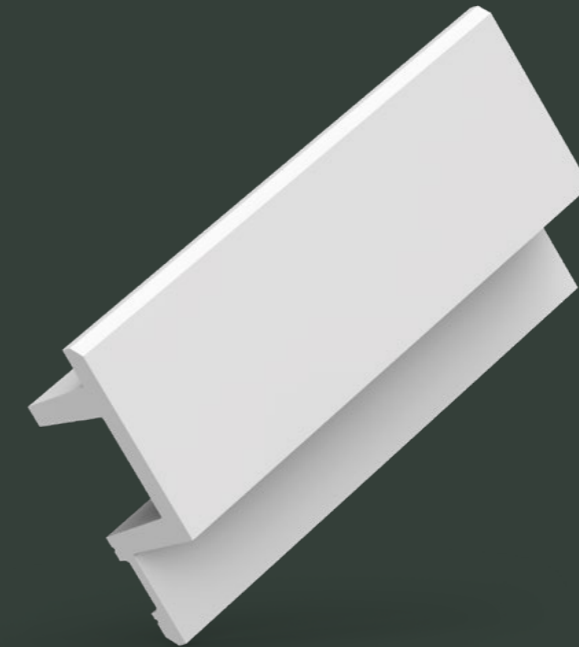
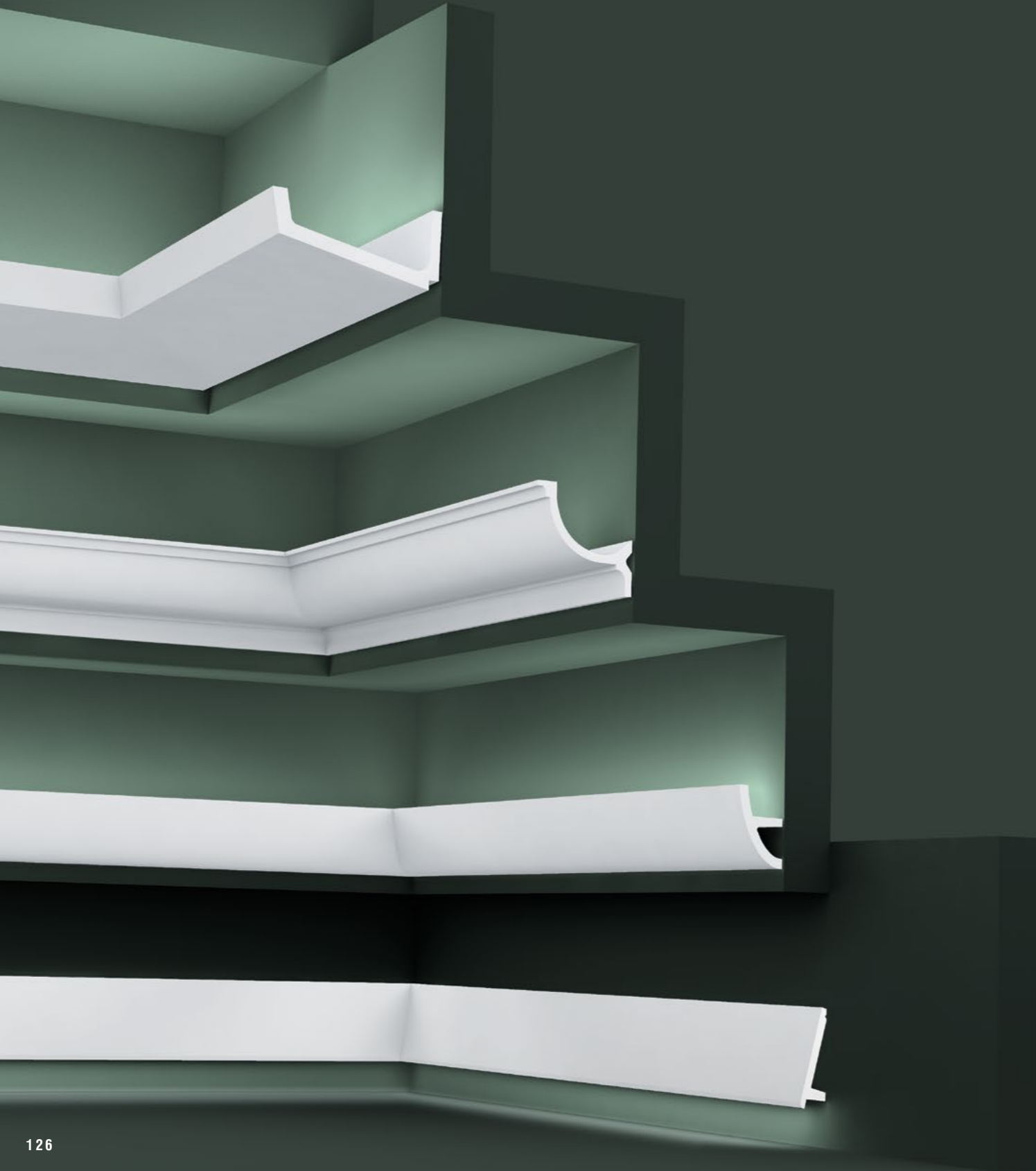

en

Indirect lighting imparts a warm atmosphere and creates an extra spatial effect. Whether tautly linear or diffuse, as uplight or downlight, one thing is certain: it enhances the architecture. What's more, the compact LED lighting ensures an energy-efficient and durable solution.

ru

Скрытое освещение создает теплую атмосферу и дополнительный эффект пространства. Каким бы не было освещение, прямым или рассеянным, сверху или снизу, ясно одно: оно совершенствует архитектуру. Более того, компактная светодиодная подсветка обеспечивает энергоэффективное и надежное решение.

pl

Listwy oświetleniowe dzięki rozproszonemu światłu tworzą przytulną atmosferę i efekt większej przestrzeni. Bez względu na to czy zastosujemy światło linearne czy rozproszone, dolne czy górne, jedno jest pewne: uatrakcyjnią to wizualną stronę architektury. Co więcej kompaktowe oświetlenie LED jest trwałym i energooszczędnym rozwiązaniem.

ar

الإضاءة غير المباشرة تضيف جواً دافئاً وتخلق إنطباعاً بمساحة إضافية. سواء كانت مستقيمة أو منتشرة، موجهة نحو الأعلى أو الأسفل، إنها بالتأكيد تعزز الهندسة الداخلية. إضافة إلى ذلك، إضاءة LED المدمجة تؤمن حلاً موفراً للطاقة ومستداماً.

fr

Incontournable pour l'ambiance, l'éclairage indirect crée une illusion d'espace supplémentaire. Qu'il soit linéaire ou organique, à luminosité vers le bas ou vers le haut, l'éclairage indirect souligne indubitablement l'architecture. Grâce à l'éclairage LED compact, vous disposez en outre d'une solution économique dont la longévité est garantie.

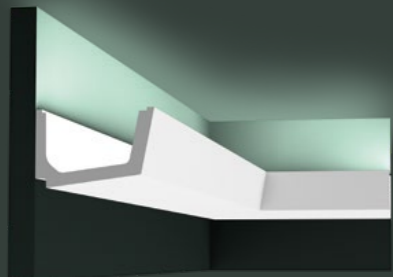

C357 STRAIGHT
200 x 7,1 x 11 cm
Purotouch®
Designed by
Jacques Vergracht

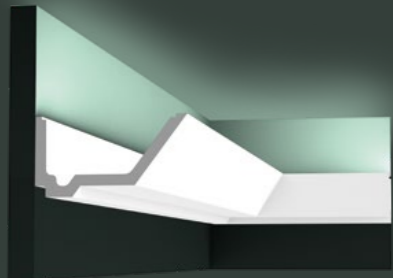
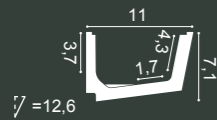

C358 RAIL
200 x 7,3 x 14 cm
Purotouch®
Designed by
Jacques Vergracht

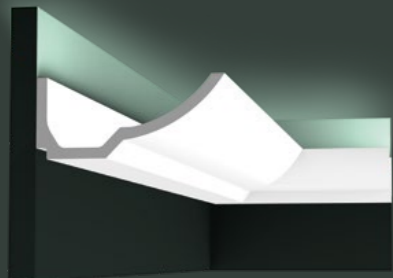
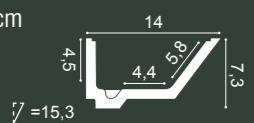

C351 BOAT
200 x 7,4 x 17,3 cm
Purotouch®
Designed by
Jacques Vergracht

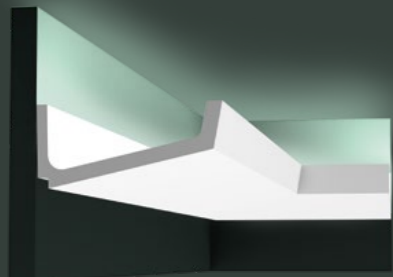
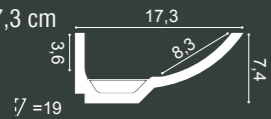

C352 FLAT
200 x 7,6 x 17,1 cm
Purotouch®
Designed by
Jacques Vergracht

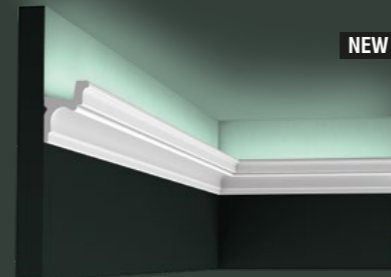
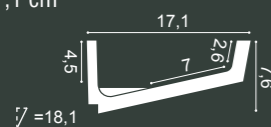

C323
200 x 5,5 x 4,2 cm
Purotouch®

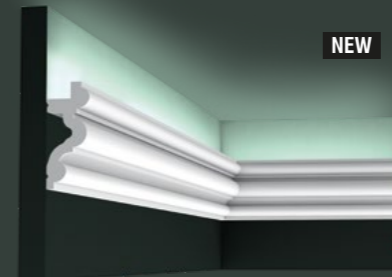

C324 AUTOIRE
200 x 8,3 x 3,4 cm
Purotouch®
Designed by
Orio Tonini

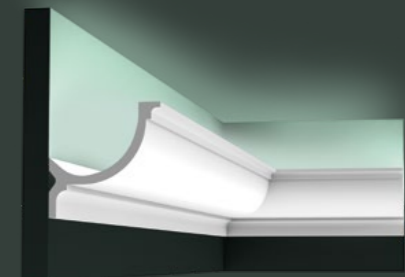
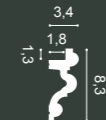

C902 | C902F
200 x 10,3 x 10,3 cm
Purotouch®

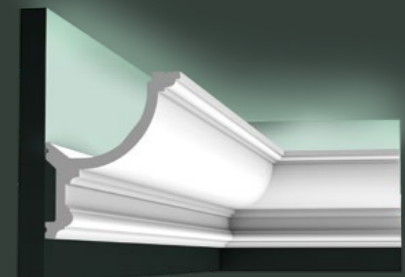
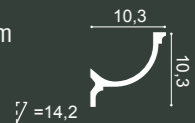

C901 | C901F
200 x 14,8 x 12,4 cm
Purotouch®

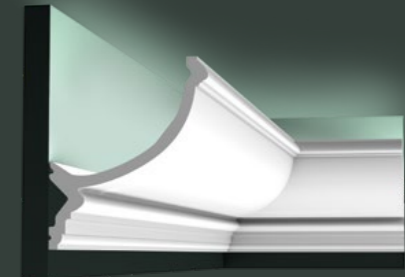
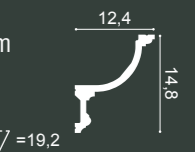

C900
200 x 17,1 x 14,6 cm
Purotouch®

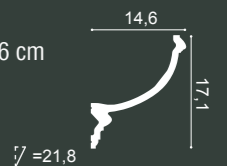

L3 Lighting Combinations

C380

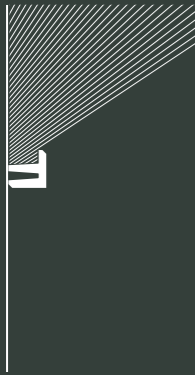

C382 + C380

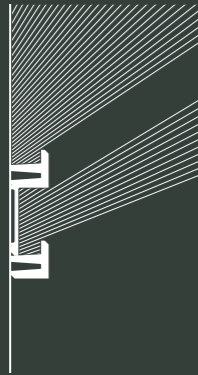

③ C382 + C382 + C380

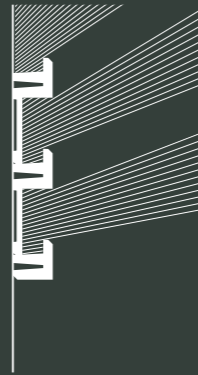

C382 + C382 + C381

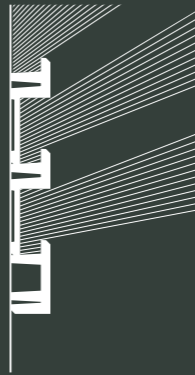

C381

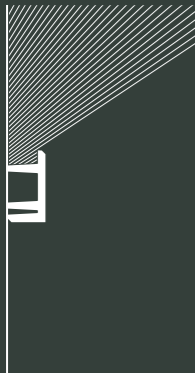

C383 + C381

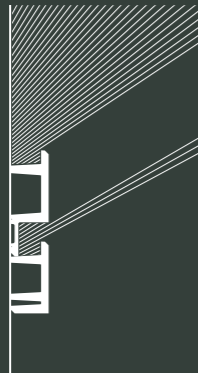

C383 + C383 + C381

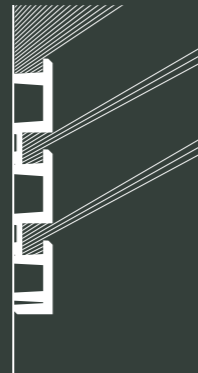

C383 + C382 + C381

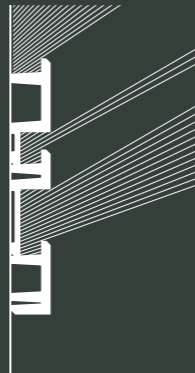

C382 + C383

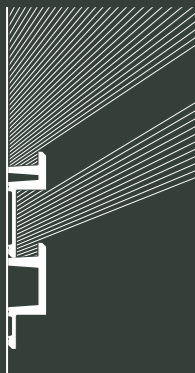

C381 + C382



C382 + C382

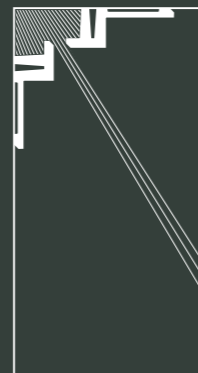

① C382 + C382 + C382

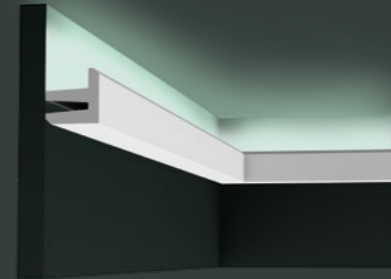
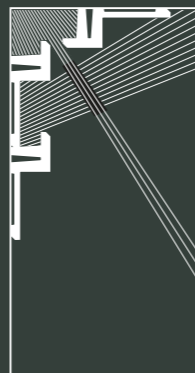

C380 L3 Linear Led Lighting

200 x 5 x 5 cm
Purotouch®
Designed by
Orio Tonini

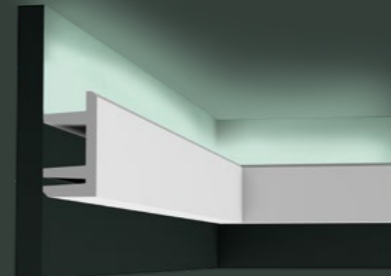
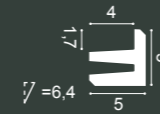

C381 L3 Linear Led Lighting

200 x 9,5 x 5 cm
Purotouch®
Designed by
Orio Tonini

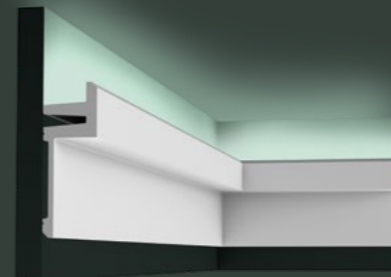
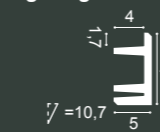

C382 L3 Linear Led Lighting

200 x 14 x 5 cm
Purotouch®
Designed by
Orio Tonini

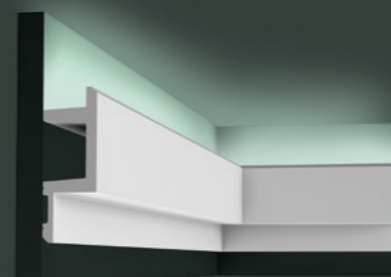
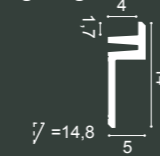

C383 L3 Linear Led Lighting

200 x 14 x 5 cm
Purotouch®
Designed by
Orio Tonini

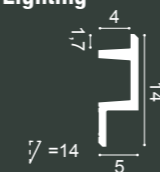

Compact Design Lighting

INDIRECT LIGHTING / СКРЫТОЕ ОСВЕЩЕНИЕ / LISTWY OŚWIETLENIOWE / إضاءة غير مباشرة / ÉCLAIRAGE INDIRECT

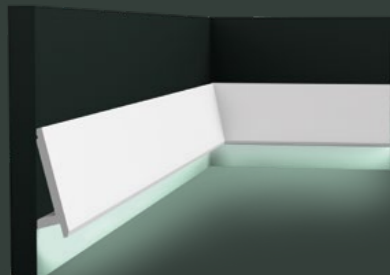

SX179 | SX179F DIAGONAL
200 x 9,7 x 2,9 cm
Duropolymer®
Designed by
Orio Tonini

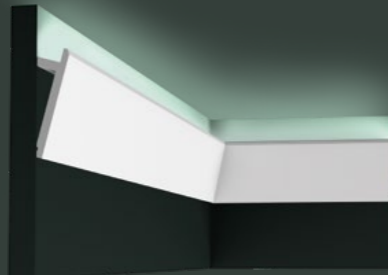

1 SX179 | SX179F DIAGONAL
200 x 9,7 x 2,9 cm
Duropolymer®
Designed by
Orio Tonini

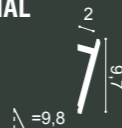

CX190 | CX190F U-PROFILE
200 x 2 x 3 cm
Duropolymer®
Designed by
Orio Tonini

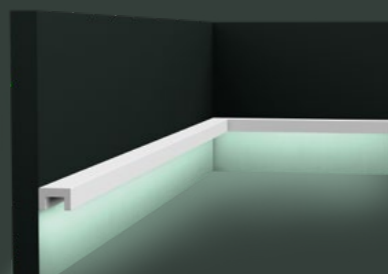

CX190 | CX190F U-PROFILE
200 x 2 x 3 cm
Duropolymer®
Designed by
Orio Tonini



CX190 | CX190F U-PROFILE
200 x 2 x 3 cm
Duropolymer®
Designed by
Orio Tonini

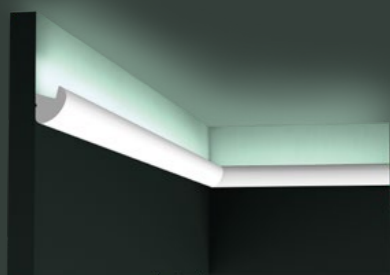

CX188 | CX188F
200 x 3,4 x 3 cm
Duropolymer®
Designed by
Orio Tonini

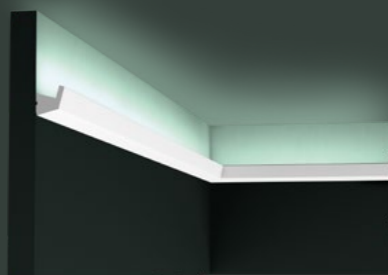

CX189 | CX189F
200 x 2,7 x 2,7 cm
Duropolymer®
Designed by
Orio Tonini



USE
ALUMINIUM
PROFILE
FOR LED

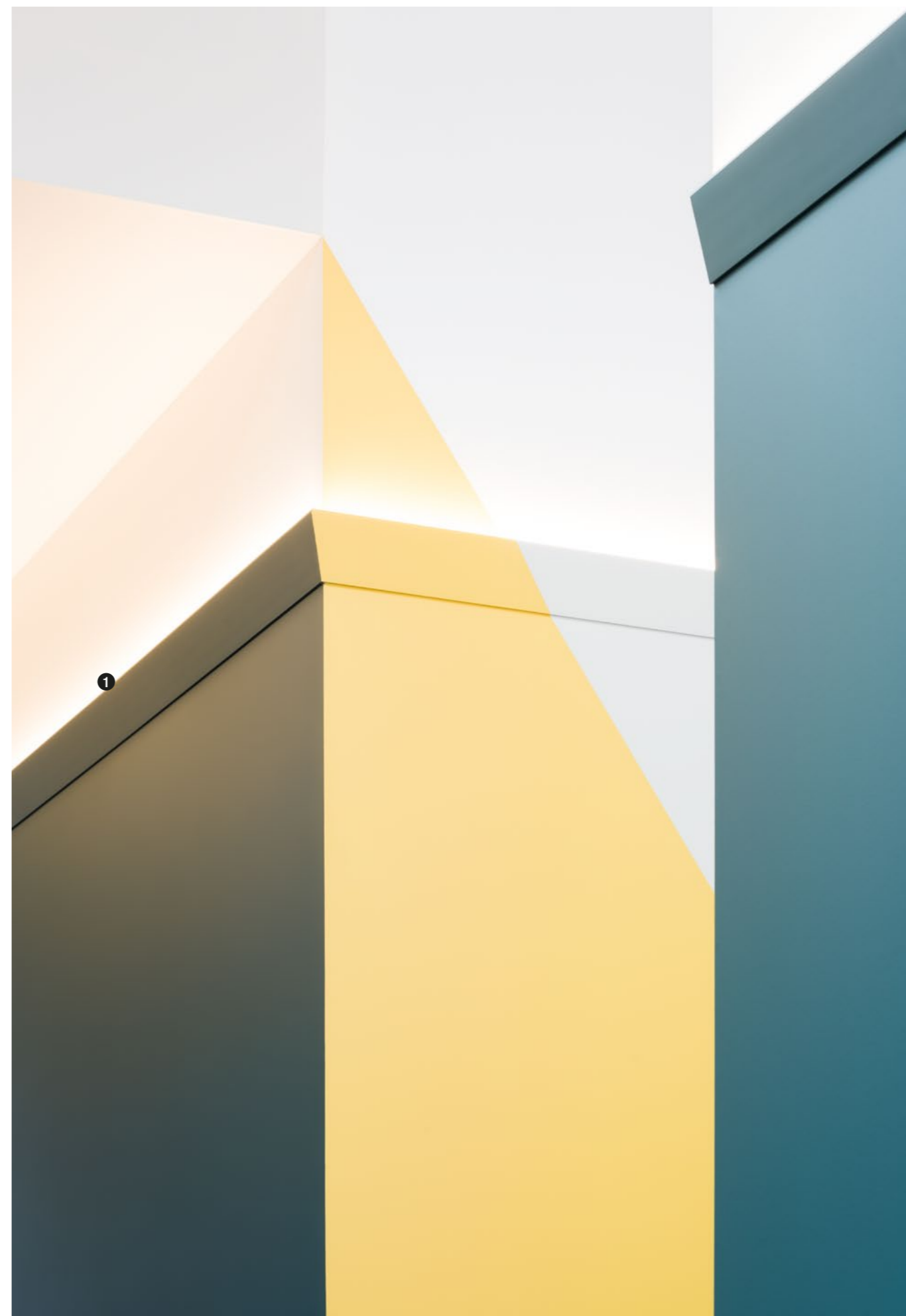

INDIRECT LIGHTING / СКРЫТОЕ ОСВЕЩЕНИЕ / LISTWY OŚWIETLENIOWE / إضاءة غير مباشرة / ÉCLAIRAGE INDIRECT

ULF MORITZ
FOR
ORAC
DECOR

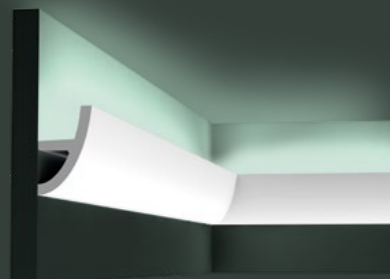

C373 | C373F ANTONIO

200 x 8 x 5 cm
Purotouch®

Designed by
Ulf Moritz

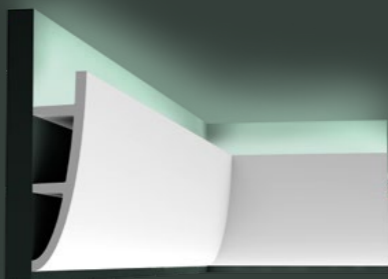
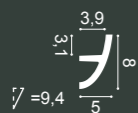

C374 | C374F ANTONIO

200 x 18 x 5 cm
Purotouch®

Designed by
Ulf Moritz

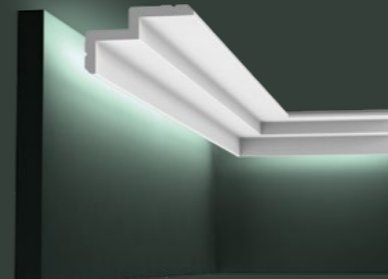
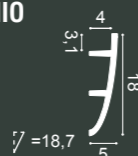

C390 STEPS

200 x 6 x 10 cm
Purotouch®

Designed by
Orio Tonini

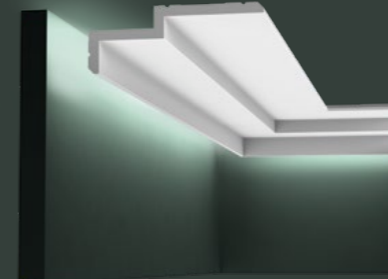
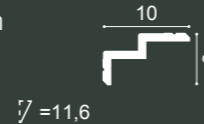

C391 STEPS

200 x 6 x 16 cm
Purotouch®

Designed by
Orio Tonini

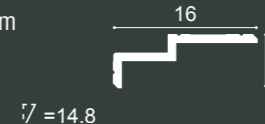

C394 STEPS

200 x 9,5 x 3,1 cm
Purotouch®

Designed by
Orio Tonini

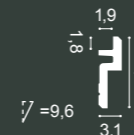

C395 STEPS

200 x 15,5 x 3,1 cm
Purotouch®

Designed by
Orio Tonini

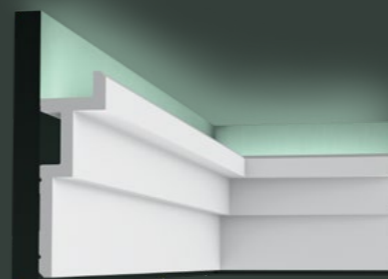

C396 STEPS

200 x 18,5 x 6,1 cm
Purotouch®

Designed by
Orio Tonini



C373 + C374

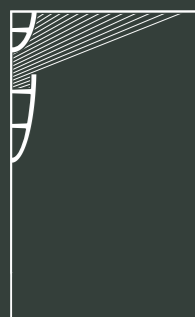

C373 + C373

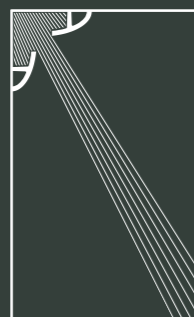

C374 + C991



C373 + C373

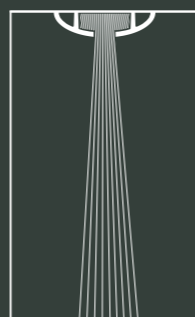

C374 + C374

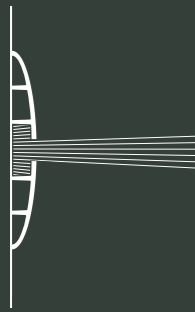

C373 + C374

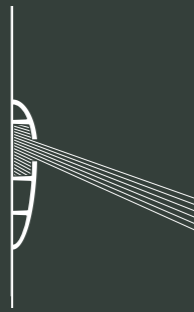

C373 + C373

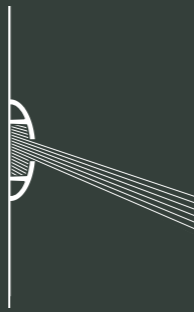

C374 + C373



C373 + C374



C374 + C374



C373 + SX167



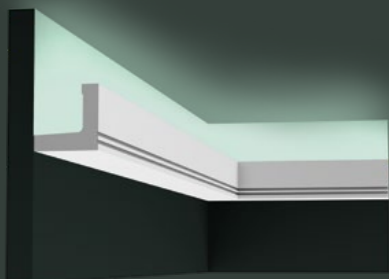

C361 STRIPE

200 x 5 x 5 cm
Purotouch®
Designed by
Pierre Daems

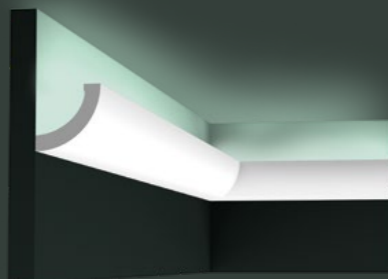
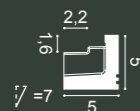

C362 CURVE

200 x 5 x 5 cm
Purotouch®
Designed by
Pierre Daems

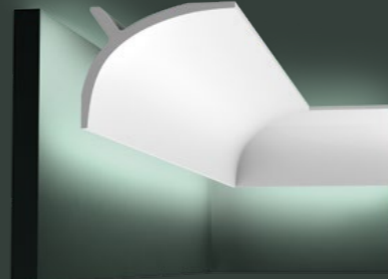
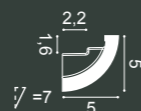

C991

200 x 11 x 14 cm
Purotouch®

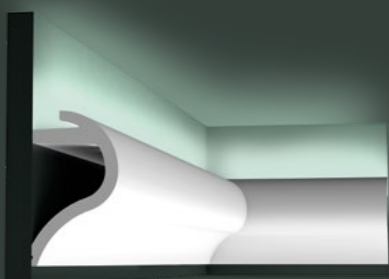
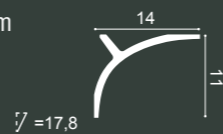

C364 WAVE

200 x 14 x 8 cm
Purotouch®
Designed by
Pierre Daems

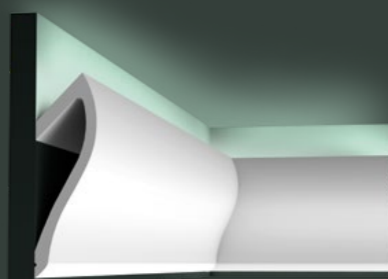
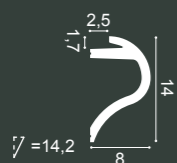

C371 SHADE

200 x 18,5 x 5,8 cm
Purotouch®
Designed by
Ulif Moritz

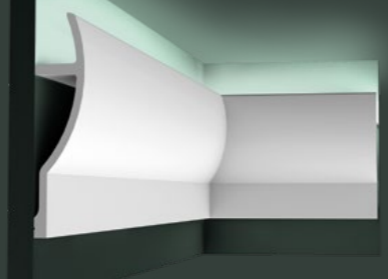
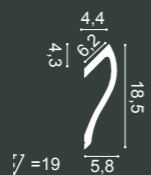

C372 FLUXUS

200 x 28 x 7 cm
Purotouch®
Designed by
Ulif Moritz

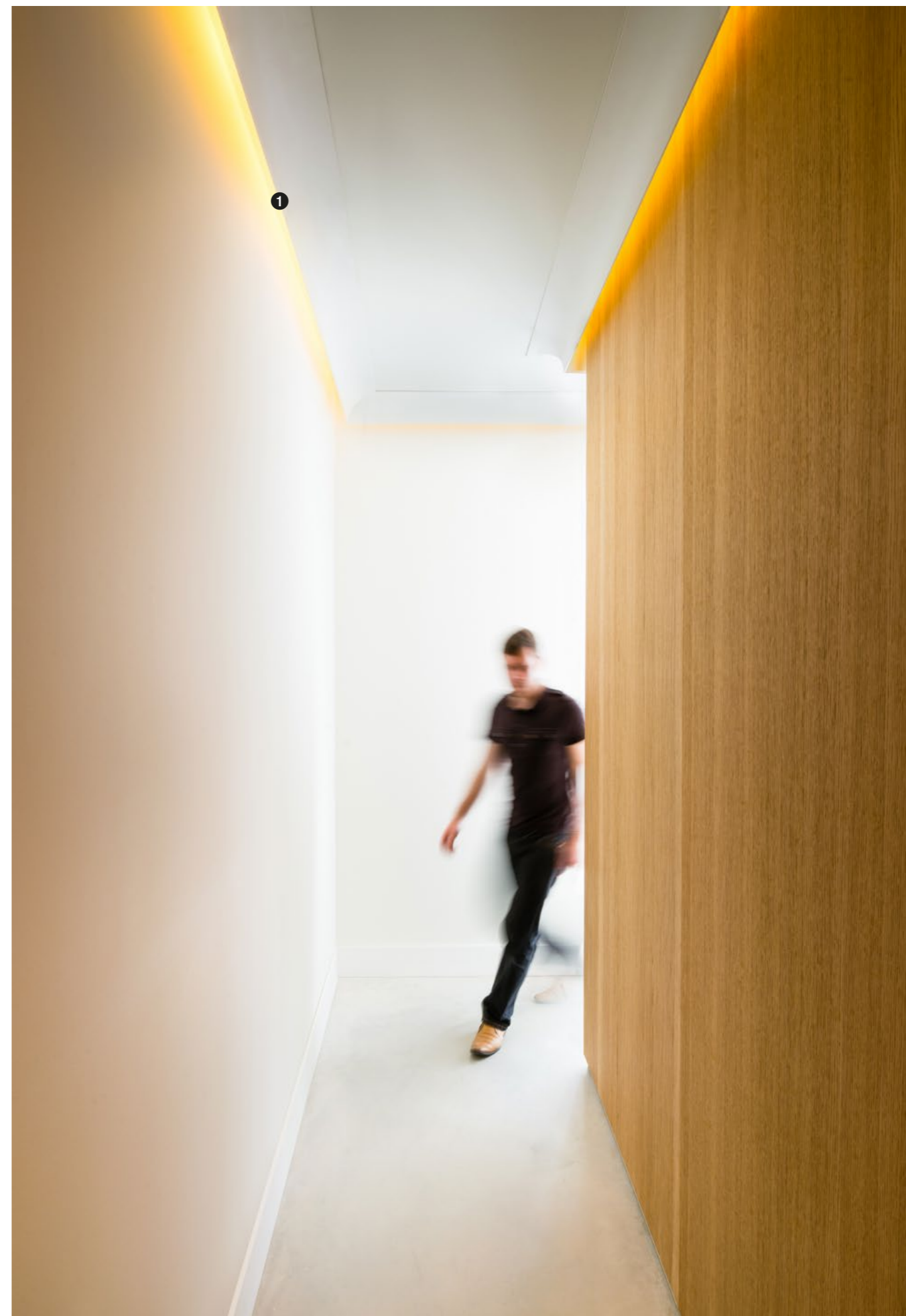
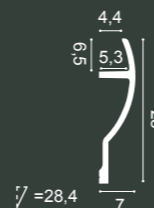

Deco Elements

ДЕКОРАТИВНЫЕ ЭЛЕМЕНТЫ
ELEMENTY DEKORACYJNE
أصناف للزينة / ÉLÉMENTS DÉCORATIFS

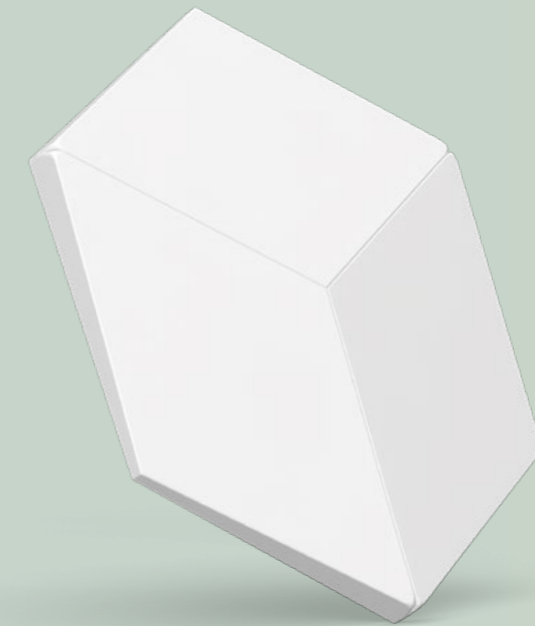

en

Follow your imagination. Understated and dignified classic interiors, can be created with our Deco elements. The sleek, modern designs suit contemporary homes, by adding a dramatic 3D form. The elements of these ornaments allow considerable opportunities to personalize any room.

ru

Дайте волю своему воображению. Любые классические интерьеры могут быть оформлены с помощью наших декоративных элементов. Стильный и минималистический, в классическом дизайне или современный с добавлением в него 3D модели? Элементы этих орнаментов предоставляют множество возможностей для персонализации любого помещения.

pl

Podążaj za swoją wyobraźnią. Dzięki naszym elementom dekoracyjnym można stworzyć zarówno subtelne jak i dostojne klasyczne wnętrza. Eleganckie i nowoczesne wzornictwo można zaaranżować we współczesnych domach dzięki wyrazistym formom 3D. Te ornamentalne elementy znacznie podnoszą możliwości personalizacji pomieszczeń.

ar

أطلقوا العنان لمخيلتكم. تصميم هادىء وأنيق لداخل كلاسيكي، معاصر لمسكن حديث، أو متنوع وثلاثي الأبعاد؟ هذه الأصناف الزينية تمكنكم من جعل كل غرفة فريدة من نوعها.

fr

Donnez libre cours à votre imagination. Sobres et dignes dans un intérieur classique, contemporains dans une habitation moderne ou plutôt un résultat 3D éclectique ? Ces ornements aux applications infinies rendent chaque pièce unique.

3D WALL PANELS



1 W100 ROMBUS
25,8 x 15 x 2,9 cm
Purotouch®



W101 TRAPEZIUM
34,5 x 15 x 2,9 cm
Purotouch®



W105 ROMBUS
30 x 34,6 x 3 cm
Purotouch®



W104 KILT
45 x 45 x 3,6 cm
Purotouch®
Designed by
Orio Tonini



W102 CUBI
33,3 x 33,3 x 2,5 cm
Purotouch®



W103 CUBI
33,3 x 33,3 x 2,5 cm
Purotouch®



W106 ENVELOP
33,3 x 33,3 x 2,9 cm
Purotouch®
Designed by
Orio Tonini

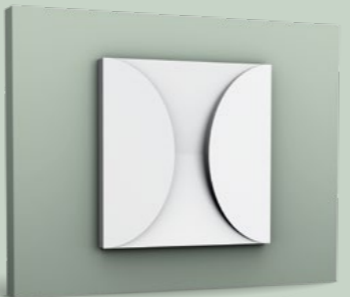

W107 CIRCLE
33,3 x 33,3 x 2,9 cm
Purotouch®
Designed by
Orio Tonini

3D WALL COVERING

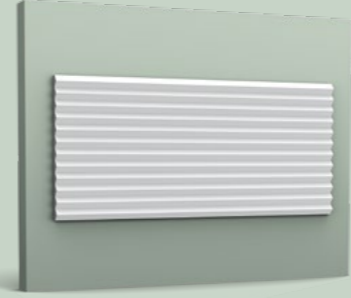

W108 ZIGZAG
200 x 25 x 1,8 cm
Purotouch®
Designed by
Orio Tonini

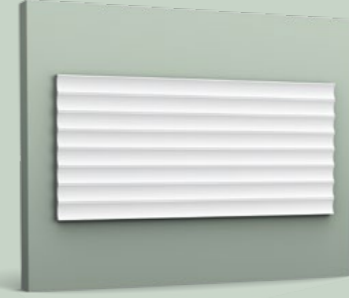

W109 VALLEY
200 x 25 x 1,3 cm
Purotouch®
Designed by
Orio Tonini

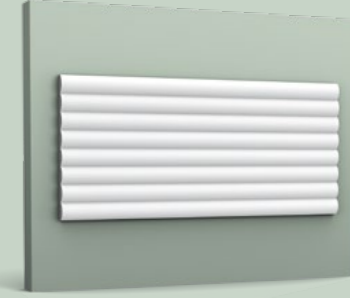

W110 HILL
200 x 25 x 1,6 cm
Purotouch®
Designed by
Orio Tonini



2 W108 ZIGZAG + 2x CX190



W109 VALLEY + 2x CX190



W110 HILL + 2x CX190

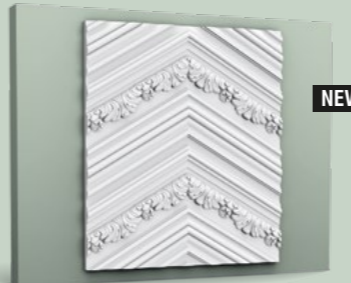

W130 CHEVRON
200 x 40 x 1,95 cm
Purotouch®



3*W130 + 2*CX190

DECO ELEMENTS / ДЕКОРАТИВНЫЕ ЭЛЕМЕНТЫ / ELEMENTY DEKORACYJNE / ديكوريات / ELEMENTS DÉCORATIFS



DECO ELEMENTS / ДЕКОРАТИВНЫЕ ЭЛЕМЕНТЫ / ELEMENTY DEKORACYJNE / ديكوريات / ELEMENTS DÉCORATIFS

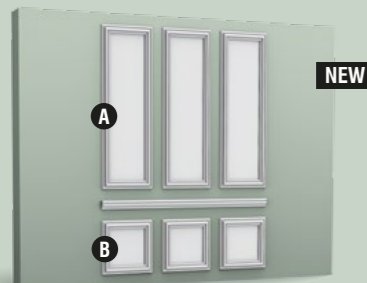

W120 + P4025 + W121
Purotouch®
Designed by
Orio Tonini



1 W120 AUTOIRE A
50 x 150 x 3,2 cm
Purotouch®
Designed by
Orio Tonini



2 W121 AUTOIRE B
50 x 50 x 3,2 cm
Purotouch®
Designed by
Orio Tonini



3 W122 AUTOIRE C
33,3 x 33,3 x 2,6 cm
Purotouch®
Designed by
Orio Tonini

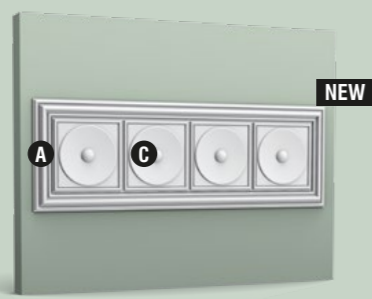

W120 + 4*W122
Purotouch®
Designed by
Orio Tonini

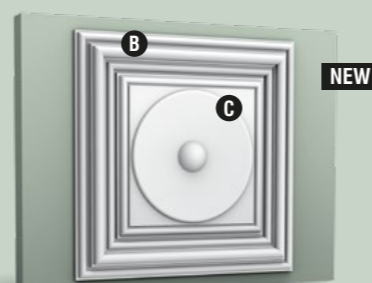

W121 + W122
Purotouch®
Designed by
Orio Tonini

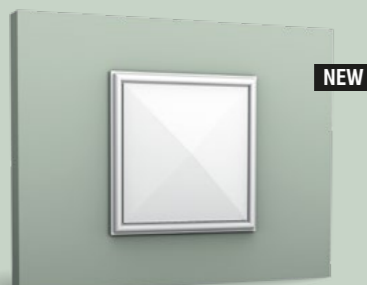

4 W123 AUTOIRE D
33,3 x 33,3 x 3,5 cm
Purotouch®
Designed by
Orio Tonini

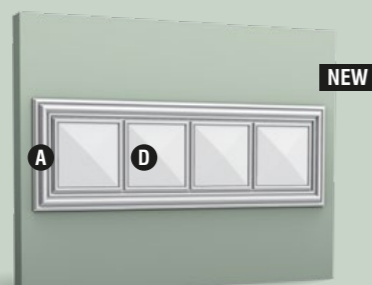

W120 + 4*W123
Purotouch®
Designed by
Orio Tonini

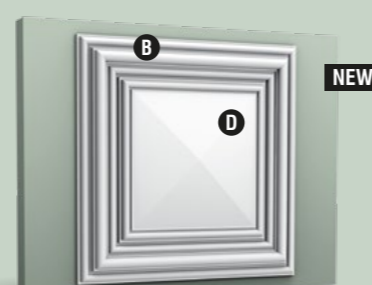

W121 + W123
Purotouch®
Designed by
Orio Tonini

DECO ELEMENTS / ДЕКОРАТИВНЫЕ ЭЛЕМЕНТЫ / ELEMENTY DEKORACYJNE / أصناف الزينة / ÉLÉMENTS DÉCORATIFS



DECO ELEMENTS / ДЕКОРАТИВНЫЕ ЭЛЕМЕНТЫ / ELEMENTY DEKORACYJNE / أصناف الزينة / ÉLÉMENTS DÉCORATIFS

CEILING ROSES / ПОТОЛОЧНЫЕ РОЗЕТКИ / ROZETY / ورديات للسقوف / ROZETY



R10 ⊕
ø 15 x 4,2 - ø 2 cm
Purotouch[®]



R11
ø 19 x 3,6 - ø 3 cm
Purotouch[®]



R12
ø 19,5 x 1,8 - ø 1 cm
Purotouch[®]



R07
ø 26 x 3 - ø 5 cm
Purotouch[®]



R08
ø 38 x 4,2 - ø 5 cm
Purotouch[®]



R13 ⊕
ø 28 x 3,1 - ø 2,5 cm
Purotouch[®]



R14 ⊕
ø 33 x 3 - ø 2,5 cm
Purotouch[®]



R31 ⊕
ø 38,5 x 2,7 - ø 3,5 cm
Purotouch[®]



R61
ø 40 x 3,1 - ø 2,5 cm
Purotouch[®]



R17 ⊕
ø 47 x 3,5 - ø 6,5 cm
Purotouch[®]



R09 ⊕
ø 48,5 x 3,7 - ø 6 cm
Purotouch[®]



R18
ø 49 x 4,7 - ø 7 cm
Purotouch[®]



R46 ⊕
ø 53,5 x 4,2 - ø 3 cm
Purotouch[®]



R66
ø 54,5 / 43 x 2,4 cm
Purotouch[®]



R76
ø 62 x 4,1 - ø 10,5 cm
Purotouch[®]



R27
ø 75 x 4,5 - ø 9 cm
Purotouch[®]



R22
77,5 x 53 x 3,6 cm
Purotouch[®]



R24
ø 79 x 6 - ø 8 cm
Purotouch[®]



R77
ø 62 x 4,2 - ø 10,5 cm
Purotouch[®]



R52 ⊕
ø 69,5 x 4,8 - ø 12,5 cm
Purotouch[®]



R73 ⊕
ø 70 x 5,9 - ø 8 cm
Purotouch[®]



R64 ⊕
ø 95,2 x 4,8 - ø 7 cm
Purotouch[®]

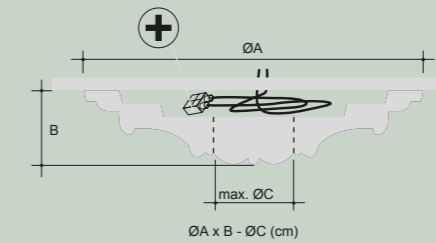

⊕ ROOM FOR CABLES
Место для кабеля
Przestrzeń na kable
مكان للكابلات
Place pour les câbles



R38
ø 71 x 4,2 - ø 19 cm
Purotouch[®]



R23
ø 71 x 4,4 - ø 6 cm
Purotouch[®]



R40 ⊕
ø 74,5 x 3,1 - ø 10 cm
Purotouch[®]

CEILING ORNAMENTS / ПОТОЛОЧНЫЕ ПЛИТКИ / PANELE SUFITOWE
زينة للسقوف / DÉCORATION DE PLAFONDS



F30
59,5 x 59,5 x 4,3 cm
Purotouch[®]



F31
59,5 x 59,5 x 6,6 cm
Purotouch[®]

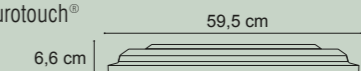



G78 LILY
8,8 x 4,4 x 1,9 cm
Duropolymer[®]
Designed by
Ulf Moritz



G76 SCALA
17,8 x 8 x 1,5 cm
Purotouch[®]
Designed by
Ulf Moritz



G77 LILY
19,4 x 8,8 x 1,8 cm
Duropolymer[®]
Designed by
Ulf Moritz

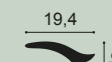

G70 FOLIO
20 x 9 x 2,7 cm
Duropolymer[®]
Designed by
Ulf Moritz

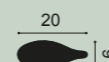

G72 SMILE
42,5 x 6,8 x 1 cm
Duropolymer[®]
Designed by
Ulf Moritz

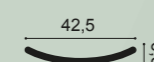

G75 SCALA
27 x 21 x 1,4 cm
Purotouch[®]
Designed by
Ulf Moritz

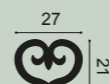

G71 SCALA
42,2 x 35 x 1,5 cm
Purotouch[®]
Designed by
Ulf Moritz



DOOR FRAMES / ДВЕРНОЕ ОБРАМЛЕНИЕ / ELEMENTY DEKORACYJNE
إطارات للأبواب / ENCADREMENTS DE PORTES

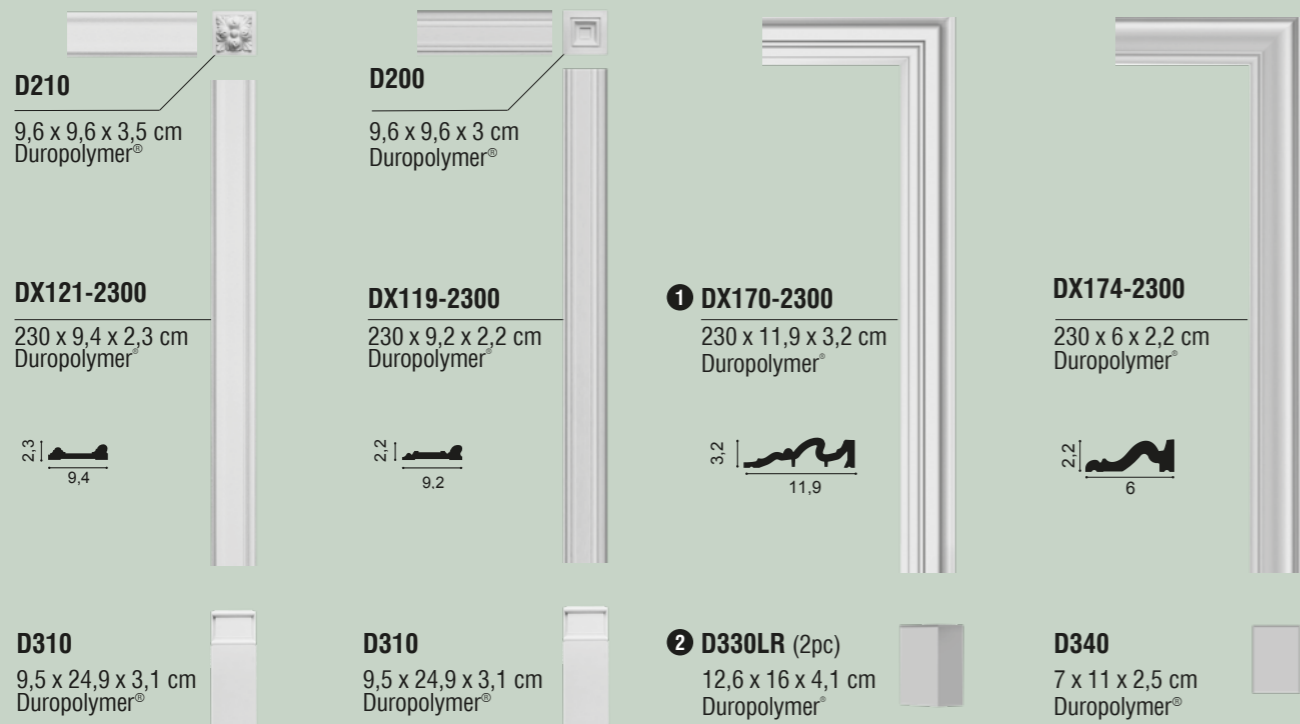

PEDIMENTS / ФРОНТОНЫ / FRONTONY / أقواس / FRONTONS

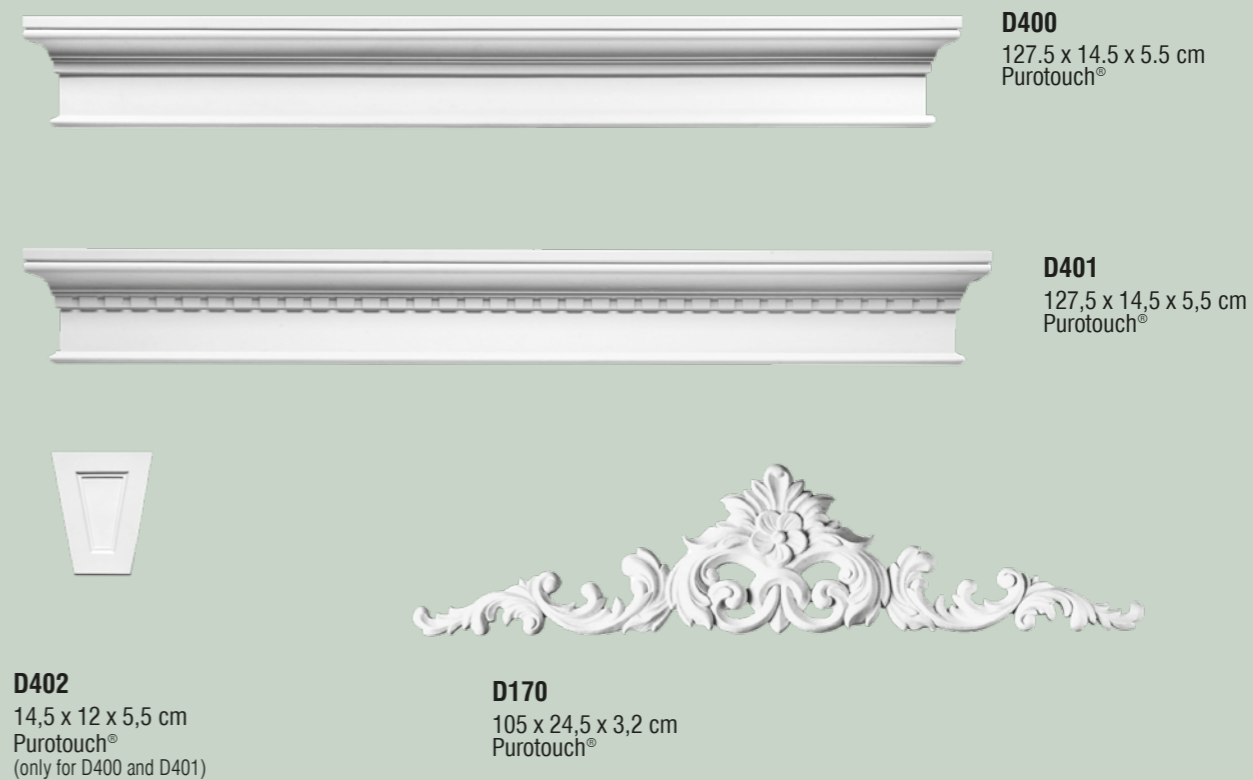

PANELLING / НАКЛАДНЫЕ ПАНЕЛИ / PANELE
ألواح / PANNEAUX



FULL COLUMNS / КОЛОННЫ
PEËNE KOLUMNY / أعمدة كاملة
COLONNES ENTIÈRES

HALF COLUMNS / ПОЛУКОЛОННЫ
PÓŁKOLUMNY / نصف أعمدة
DEMI-COLONNES

PILASTERS / ПИЛЯСТРЫ / PILASTRY
أعمدة مسطحة للجدران / PILASTRES

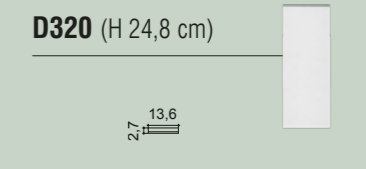
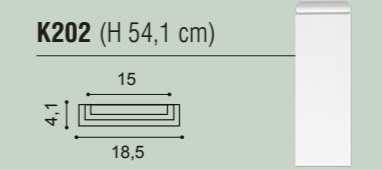
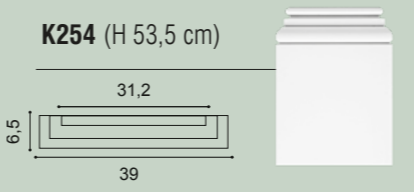
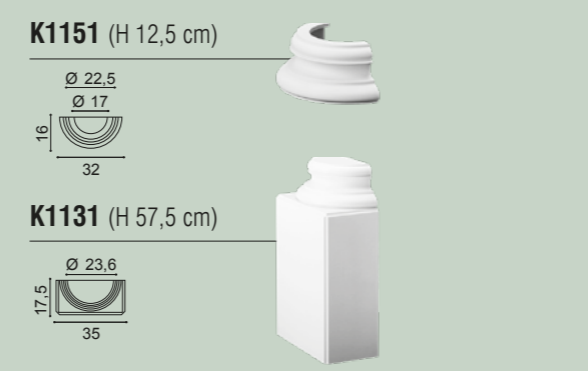
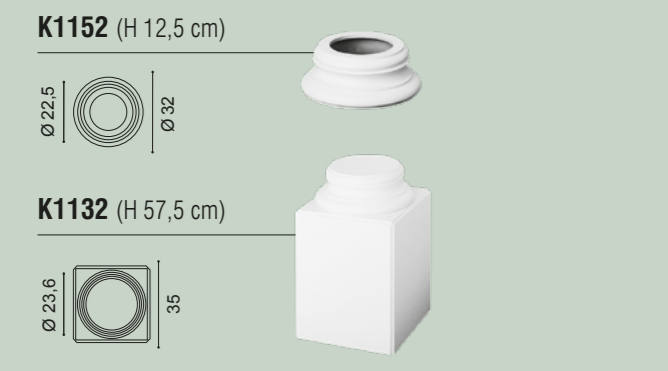
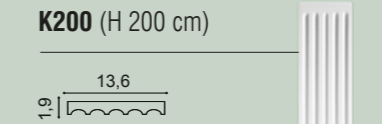
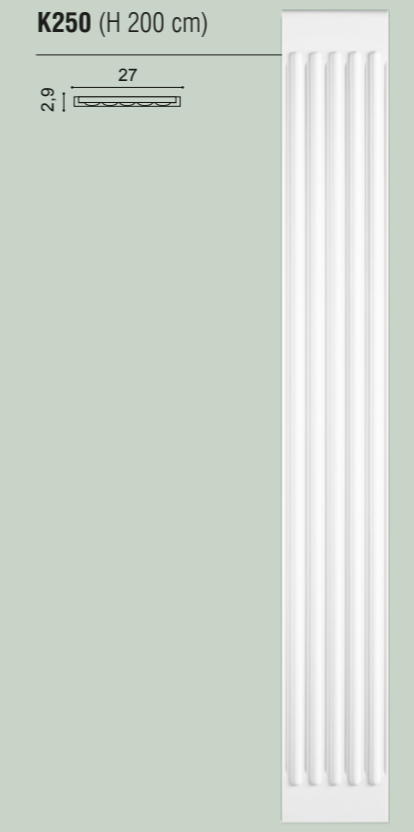
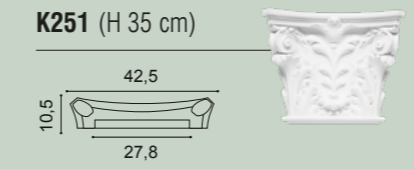
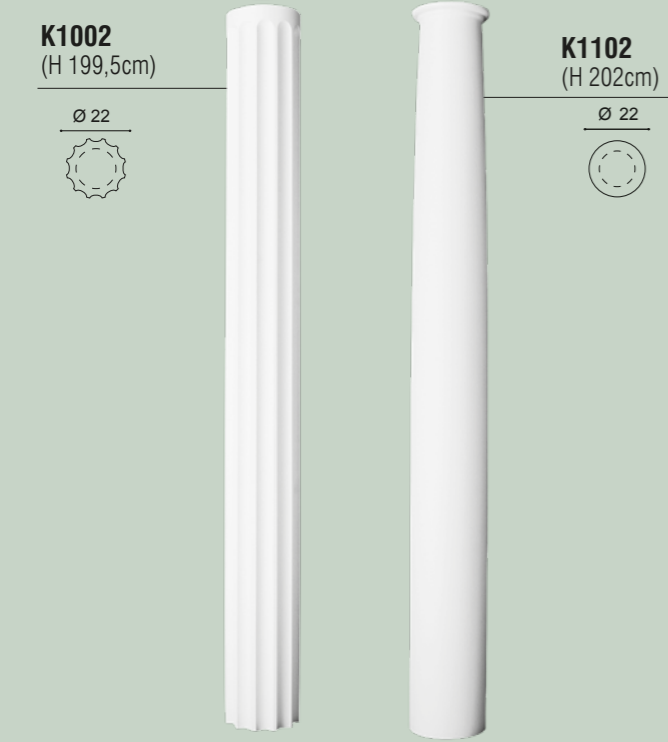
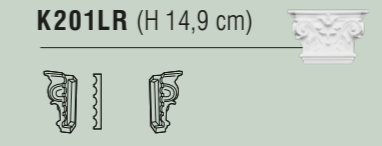
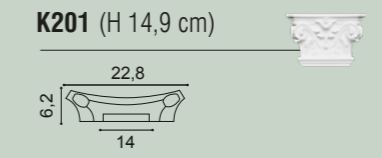
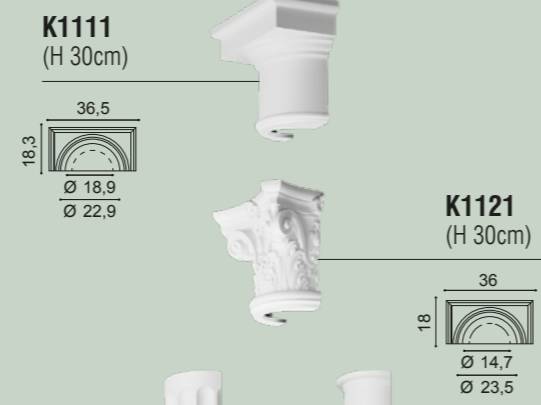

K1112 + K1002 + K1152 = 242 cm H
K1112 + K1002 + K1132 = 287 cm H max
K1122 + K1102 + K1152 = 242 cm H
K1122 + K1102 + K1132 = 287 cm H max

K1111 + K1001 + K1151 = 242 cm H
K1111 + K1001 + K1131 = 287 cm H max
K1121 + K1101 + K1151 = 242 cm H
K1121 + K1101 + K1131 = 287 cm H max

The Perfect Finish

Идеальный финиш / Idealne wykończenie
مظهر نهائي مثالي / La finition parfaite

Ready? Set? Go!



ONLY FULL GUARANTEE WITH DECOFIX
ГАРАНТИЯ НА ПРОДУКЦИЮ ДЕЙСТВУЕТ ТОЛЬКО ПРИ ИСПОЛЬЗОВАНИИ КЛЕЯ DECOFIX
PEŁNA GWARANCJA TYLKO Z KLEJEM DECOFIX
ضمانة كاملة فقط مع ديكوفيكس
GARANTIE TOTALE UNIQUEMENT AVEC COLLE DECOFIX

Ready?

SURFACE & ATMOSPHERE

Поверхность и окружающая среда | Powierzchnia & atmosfera | السطح والمحيط | Environnement & Surface



Storage and installation conditions: Store profiles and adhesives at room temperature and wait 24 hours before installing.

Условия хранения и монтажа: Оставьте профили и клей в комнате, которой планируется монтаж, на 24 часа.
Warunki przechowywania i użycia kleju: profile i kleje przechowywać w temperaturze pokojowej, odczekać 24 godziny przed instalacją.
شروط التخزين والتثبيت: يجب وضع القوالب والمواد اللاصقة في درجة حرارة الغرفة ٢٤ ساعة قبل التركيب.
Conditions d'installation et de stockage: Stockez les profils et les colles à température ambiante 24 heures avant la pose.

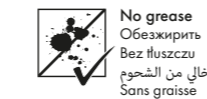
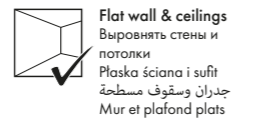
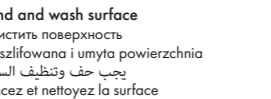

Set?

DECOFIX ADHESIVES

Клей Decofix | Kleje Decofix | المواد اللاصقة ديكوفيكس | Colles Decofix

Interior, porous and dry surface
Подходит для внутренних работ, пористых и сухих поверхностей | Wewnątrz, do powierzchni porowatych i suchych |
يصلح لسطح جدران/سقف مسامي وجاف | Pose à l'intérieur, surfaces poreuses, pièces non humides

Exterior, non-porous and humid surface
Подходит для наружных работ, непористых и влажных поверхностей | Na zewnątrz, do powierzchni nieporowatych i wilgotnych |
يصلح لسطح خارجي، غير مسامي ورطب | Pose à l'extérieur, surfaces non poreuses, environnement humide

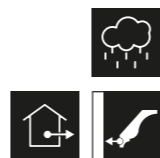

DecoFix Pro
Strong, water-based acrylic installation adhesive

FDP500 310ml | 7 > 8m
FDP600 4200ml | 65 > 110m

or
of
ou
oder
o

DecoFix Power*
Very strong MS-Polymer-based installation adhesive

FDP700 290ml | 7 > 8m
*Nieuwe naam voor DecoFix Hydro / Nouveau nom pour Decofix Hydro / Neuer Name für DecoFix Hydro / Nuevo nombre para DecoFix Hydro

DecoFix Extra
Polyurethane-based adhesive

FX200 310ml | min. 80m
FX210 tube 80ml | min. 20m

*For Durofoam®: use DecoFix Pro for joints
используйте стыковочный клей Decofix | Do przyklejania Durofoam® [pianki Duro] | لدوروفوم: يجب استعمال ديكوفيكس برو لملء الفواصل | Pour Durofoam®: utilisez DecoFix Pro pour les joints

DecoFix Pro



FDP500 310ml
> 7 - 8m
FDP600 4200ml
> 65 - 110m

Extra strong installation adhesive for porous surfaces and interior applications

- Strong, water-based acrylic glue
- Long-lasting seal between mouldings and the wall and/or ceiling
- Remove with humid sponge or cloth
- Should be kept frost free
- Paintable after hardening (min. 24 hours)

DecoFix Power*



FDP700 290ml
> 7 - 8m

Extra strong MS polymer glue for exterior applications, non-porous (tiles, glass, ...) surfaces and damp environments

- Remove with soap solution
- Paintable after hardening (min. 24 hours)

DecoFix Extra



FX200 310ml
> 80m
FX210 80ml
> 20m

Polyurethane-based glue to seam joints between mouldings

- Remove excess glue before hardening (max. 1 hour and repeat after 2-3 hours)
- Clean with acetone or Synth Thinner
- Can be painted after 24 hrs
- The more humidity, the faster the drying time

Монтажный клей для пористых поверхностей и внутреннего применения

- Стойкий, акриловый клей на водной основе
- Долговечное соединение между молдингами и стеной и/или потолком
- Удаляется с помощью влажной губки или тряпки
- Хранить не замораживая
- Лепной декор можно окрашивать через 24 часа

Монтажный полимерный клей и наполнитель для наружного применения, в помещениях с повышенной влажностью, непористых поверхностях (плитка, стекло, ...) вместо DecoFix Pro

- Излишки клея удаляются мыльным раствором до застывания
- Лепной декор можно окрашивать через 24 часа

Стыковочный клей на полиуретановой основе для соединительных швов лепного декора

- Избыток клея предпочтительно удалить до затвердевания (макс. 1 час и повтор каждые 2-3 часа)
- Излишки и пятна клея следует удалять с помощью ацетона или растворителя
- Лепной декор можно окрашивать через 24 часа
- Чем больше влажность, тем меньше время высыхания

Wyjątkowo mocny klej instalacyjny do aplikacji we wnętrzach na porowatych powierzchniach

- Mocny, akrylowy klej na bazie wody
- Długotrwałe uszczelnienie pomiędzy listwami, a ścianami lub sufitami
- Nadmiar usuwać za pomocą wilgotnej gąbki lub szmatki
- Chronić przed mrozem
- Nadaje się do malowania po całkowitym stwardnieniu (min. 24 godz.)

Wyjątkowo mocny klej MS polimerowy do stosowania na zewnątrz, na gładkich powierzchniach (płytki, szkło itp.) w wilgotnym środowisku

- Usuwać roztworem z mydła
- Nadaje się do malowania po całkowitym stwardnieniu (min. 24 godz.)

Poliuretanowy klej do łączeń pomiędzy listwami

- Nadmiar kleju usuwać przed stwardnieniem (maks. 1 godz., powtórzyć po 2-3 godz.)
- Czyścić acetonem lub syntetycznymi rozpuszczalnikami
- Nadaje się do malowania po 24 godz.
- Wyższa wilgotność skraca czas schnięcia

لاصق قوي جدا لتركيب القوالب على أسطح مسامية وفي الداخل غير مسامية (بلاط، زجاج، ...)

- لاصق أكريليك قوي، أساسه ماء
- لاصق متين بين القوالب والجدران أو السقف
- يزال باللماء والصابون
- يمكن طلاؤه بعد أن يصلب (٢٤ ساعة على الأقل)

لاصق م.س. بوليمير قوي جدا لتركيب القوالب في الخارج، وعلى أسطح غير مسامية (بلاط، زجاج، ...)

- لاصق أكريليك قوي، أساسه ماء
- لاصق متين بين القوالب والجدران أو السقف
- يزال باللماء والصابون
- يمكن طلاؤه بعد أن يصلب (٢٤ ساعة على الأقل)

لاصق بوليوريثين للسطح الفواصل بين القوالب

- يزال فائض الغراء قبل أن يصلب (بعد ساعة كحد أقصى، ومجددا بعد ٢-٣ ساعات)
- ينظف بأستون أو مرقق اصطناعي
- يمكن طلاؤه بعد ٢٤ ساعة
- ينشف بسرعة أكبر مع ارتفاع درجة الرطوبة

Colle d'installation ultra forte pour surfaces poreuses et applications intérieures

- Colle forte à base d'eau et d'acrylique
- Joint longue durée entre les moulures et le mur et/ou le plafond
- Retirez à l'aide d'une éponge ou d'un chiffon humide
- Doit être conservée à l'abri du gel
- Peut être peinte après séchage (min. 24 heures)

Colle au MS polymère extra forte pour utilisation extérieure, surfaces non poreuses (carrelage, verre, etc...) et environnements humides

- Enlevez à l'aide d'une solution savonneuse
- Peut être peinte après séchage (min. 24 heures)

Colle polyuréthane pour l'assemblage des joints entre les moulures

- Éliminez les excès de colle avant le durcissement (1 heure max. et recommencez après 2-3 heures)
- Nettoyez avec de l'acétone ou un diluant synthétique
- Peut être peint après 24 h
- Un taux d'humidité plus élevé peut accélérer le temps de séchage

*Nieuwe naam voor DecoFix Hydro / Nouveau nom pour Decofix Hydro / Neuer Name für DecoFix Hydro / Nuevo nombre para DecoFix Hydro

ACCESSORIES | Аксессуары | Akcesoria | لوازم | Accessoires



FB15

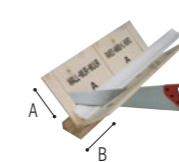

FB300
A: 29,7 cm
B: 29,1 cm

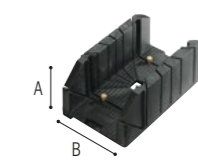

FB13
A: 12,5 cm
B: 15,5 cm

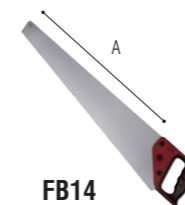

FB14
A: 60 cm



FB10
A: 27,5 cm - B: 22 cm

Go!



INSTALLATION VIDEOS & MANUALS
DECOFIX GLUE CALCULATOR

SCAN THE QR CODE OR
VISIT WWW.ORACDECOR.COM > INSTALLATION

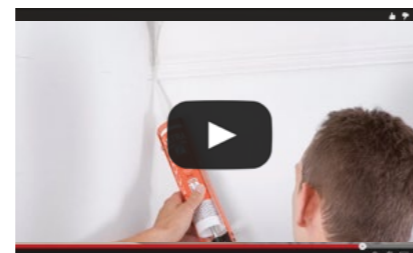

Flexible Products

Flex Radius	R min in cm	R* min in cm	Flex Radius	R min in cm	R* min in cm	Flex Radius	R min in cm	R* min in cm
C200F	160		C602F	100		P8050F	80	200
C201F	200		C901F	600		P8060F	80	200
C211F	250		C902F	600		P9010F	40	310
C212F	120		CX100F	200		P9020F	30	
C213F	280		CX106F	360		P9040F	30	80
C214F	140		CX109F	160		P9050F	20	60
C215F	160		CX110F	180		P9900F	20	250
C216F	340		CX123F	280		P9901F	20	180
C217F	380		CX124F	160		PX103F	20	80
C218F	360		CX127F	240		PX120F	30	110
C220F	400		CX132F	70		PX144F	20	220
C230F	150		CX148F	180		PX175F	30	80
C240F	270		CX188F	110		SX104F	40	
C250F	70		CX189F	90		SX105F	30	
C260F	130		CX190F	30	130	SX118F	40	
C301F	320		DX174F	60	300	SX137F	40	
C302F	250		P1020F	30	80	SX138F	40	
C303F	180		P2020F	30	80	SX155F	30	
C304F	250		P3020F	50	180	SX157F	35	260
C308F	120		P4020F	40	200	SX162F	20	80
C321F	140		P4025F	70		SX163F	35	
C322F	160		P5020F	30		SX165F	40	
C325F	300		P5021F	20	70	SX172F	35	
C326F	500		P6020F	30	250	SX173F	45	
C331F	420		P7010F	20		SX179F	35	
C333F	300		P7020F	30		SX180F	45	
C334F	380		P7030F	30	250	SX182F	35	
C339F	380		P7040F	40	320	SX183F	40	
C341F	400		P7070F	30	230	SX184F	45	
C373F	100		P8020F	40	130	SX187F	40	
C374F	130		P8030F	20	70			
C402F	300		P8040F	30				

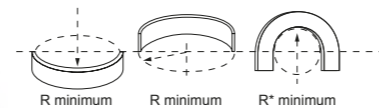

Discover our flexible collection.
Откройте коллекцию наших гибких профилей.
Odkryj naszą elastyczną kolekcję.
اكتشفوا مجموعة قوالبنا المرنة.
Découvrez notre collection flexible.

WWW.ORACDECOR.COM



en

A wide range of cornice mouldings, panel mouldings and skirting boards are available to give curved walls and ceilings an elegant finish. These elements are also light and can be painted.

The sky is the limit: add curved lines and circles to your walls and ceilings in no time.

ru

Широкий ассортимент гибких карнизов, молдингов и плинтусов позволяет оформить округлые стены и потолки. Эти профили лёгкие и легко окрашиваются.

Границы - это небо: добавьте изогнутые линии и круги к Вашим стенам и потолку в мгновение ока.

pl

Dostępna szeroka gama listew przysufitowych, panelowych i przypodłogowych daje możliwość eleganckiego wykończenia krzywymi ścianami i sufitami. Elementy te są jasne i mogą być malowane.

Jedynym ograniczeniem jest wyobraźnia: dodaj do ścian i sufitów pozakrzywiane, zaokrąglone linie i okręgi.

ar

مجموعة واسعة من الكرنيش، قوالب الجدران والنعلات متوفرة لإعطاء الجدران والسقوف المقوسة مظهر أنيق. هذه الأصناف هي أيضا خفيفة الوزن ويمكن طلاؤها.
السماء هي الحد: أضيفوا خطوط منحنية ودوائر إلى الجدران والسقوف بسرعة وسهولة.

fr

De nombreuses corniches, cimaises et plinthes sont disponibles dans des modèles variés. Les murs et plafonds courbes peuvent également bénéficier d'une finition élégante. En outre, ils sont clairs et peuvent être peints!

Vous n'auriez jamais imaginé qu'il serait aussi facile d'installer des lignes courbes et des cercles au mur et au plafond.

Index

C

C200 C200F	87
C201 C201F	90
C211 C211F	90
C212 C212F	88
C213 C213F	88
C214 C214F	87
C215 C215F	86
C216 C216F	90
C217 C217F	88
C218 C218F	91
C219	93
C220 C220F	88, 91
C230 C230F	86
C240 C240F	88
C250 C250F	86
C260 C260F	86
C300	93
C301 C301F	93
C302 C302F	90
C303 C303F	91
C304 C304F	90
C305	89
C305 + C211	89
C305 + C213	89
C307	94
C307 + C307A	94
C308 C308F	95
C321 C321F	88
C322 C322F	86, 87, 103, 135
C323	87
C324	88
C325	87
C326	88
C327	91
C331 C331F	87, 88
C332	90
C333 C333F	90
C334 C334F	91
C335	95
C336	95
C337	93
C338	94
C338A	94
C338B	94
C339 C339F	90
C340	90
C341 C341F	88, 103
C342	90, 103
C343	94, 103
C344	95
C351	128

C352	128
C353	86
C354	86, 103, 135
C355	86
C356	86
C357	128
C358	128
C360	86
C361	136
C362	136
C364	136
C371	136
C372	136
C373 C373F	134
C374 C374F	134
C380 L3	131
C381 L3	131
C382 L3	131
C383 L3	131
C390	87, 103, 135
C391	87, 103, 135
C392	95
C393	91
C394	86, 103, 135
C395	86, 103, 135
C396	87, 103, 135
C400	87
C402 C402F	88
C422	93
C602 C602F	87, 132
C900	93, 129
C901 C901F	91, 129
C902	129
C902 C902F	88
C990	92
C990 + 2x P9900	92
C990 + P9900	92
C991	89, 103, 136
C991 + 2x P9900	89
C991 + P9900	89
CB500	101
CB501	101
CB502	101
CB503	101
CB510	101
CB511	101
CB512	101
CB520	101
CB521	101
CB522	101
CB523	101
CB524	101
CB530	101
CB531	101

CX100 CX100F	99
CX101	99
CX106 CX106F	100
CX107	100
CX108	99
CX109 CX109F	98
CX110 CX110F	99
CX111	98
CX112	99
CX115	98
CX123 CX123F	99
CX124 CX124F	99
CX126	99
CX127 CX127F	100
CX128	100
CX129	100
CX132 CX132F	98, 118
CX133	98, 118
CX134	110
CX136	99
CX141	99
CX148 CX148F	98
CX150	98
CX151	98
CX154	98
CX160	97
CX161	97
CX176	99
CX177	99
CX188 CX188F	132
CX189 CX189F	132
CX190 CX190F	98, 110, 118, 132

D

D170	151
D200	150
D210	150
D310	150
D320	153
D330LR	150
D340	150
D400	151
D401	151
D402	151
D503	151
D504	151
D506	151
D507	151
DX119-2300	112, 150
DX121-2300	112, 150
DX170-2300	112, 150
DX174-2300	150
DX174-2300 DX174F	111

F

F30	147
F31	147
FB10	155
FB13	155
FB14	155
FB15	155
FB300	155

G

G70	149
G71	149
G72	149
G75	149
G76	149
G77	149
G78	149

K

K200	153
K201	153
K201LR	153
K202	153
K250	153
K251	153
K254	153
K1001	152
K1002	152
K1101	152
K1102	152
K1111	152
K1112	152
K1121	152
K1122	152
K1131	152
K1132	152
K1151	152
K1152	152

P

P20 + P101A	113
P21 + P201A	113
P101A + P1020	113
P201A + P2020	113
P801C + P8020	113
P1020 P1020F	106
P2020 P2020F	106
P3020A + P3020	113
P3020 P3020F	106
P3070	108
P3071 GOLF	108
P4020A + P4020	113
P4020 P4020F	106
P4025	107
P5020B	113
P5020 P5020F	108

P5021 P5021F	106
P5050	108
P5051	107
P6020 P6020F	106
P7010 P7010F	108
P7020 P7020F	108
P7030 P7030F	107
P7040 P7040F	107
P7070 P7070F	107
P7080	108
P8020 P8020F	106
P8030C + P8030	113
P8030D + P8030	113
P8030 P8030F	106
P8040 P8040F	108
P8050 P8050F	108
P8060 P8060F	106
P9010 P9010F	107
P9020 P9020F	108
P9040 P9040F	106
P9050 P9050F	106
P9900 P9900F	107
P9901 P9901F	106
PB513	101
PX102	112
PX103A + PX103	113
PX103 PX103F	110
PX113	111
PX114	111
PX116	110
PX117	111
PX120A + PX120	113
PX120 PX120F	111
PX131	111
PX144 PX144F	111
PX147	110
PX164	100
PX169	110
PX175 PX175F	111

R

R07	145
R08	145
R09	145
R10	145
R11	145
R12	145
R13	145
R14	145
R17	145
R18	145
R22	147
R23	146
R24	147
R27	147
R31	145
R38	146
R40	146
R46	146

R52	146
R61	145
R64	147
R66	146
R73	146
R76	146
R77	146

S

SX104 SX104F	120
SX105 SX105F	119
SX118 SX118F	116, 120
SX122	118
SX125	118
SX137 SX137F	119
SX138 SX138F	120
SX155 SX155F	119
SX156	120
SX157 SX157F	97, 111, 116, 118, 124
SX159	118
SX162 SX162F	97, 111, 118, 124
SX163 SX163F	98, 112, 119, 124
SX165 SX165F	116, 118
SX167	120
SX168	112, 120, 125
SX171	116, 119, 123
SX172 SX172F	119
SX173 SX173F	116, 119
SX179 SX179F	119, 132
SX180 SX180F	120, 125
SX181	120, 125
SX182 SX182F	97, 116, 118, 124
SX182 SX182F	111
SX183 SX183F	97, 118, 124
SX184 SX184F	98, 112, 124
SX185	116, 120, 123
SX186	116, 120, 123
SX187 SX187F	118
SX191	120

W

W100	140
W101	140
W102	140
W103	140
W104	140
W105	140
W106	140
W107	140
W108	141
W120	142
W121	142
W122	142
W123	142
W130	141

CONCEPT

Bjorn Verlinde
Brando
Gazeuse

GRAPHICS

Gazeuse

SPECIAL THANKS TO

Balo Living in Style	www.balo.be	12, 13, 24, 25
Toon Degruyter	www.toondegruyter.be	12, 13, 24, 25
Eichholtz	www.eichholtz.com	14, 15
Groep Versluys	www.groepversluys.be	16, 17
Naudts Patrick	Belex	22, 23, 35
Perfect Living by Nathalie Bakker	www.perfectliving.be	28, 29, 49
Peckers Pascale	pascale@peckers.me, Ph.: Mireille Roobaert	30, 31
Stadsbader Marie	www.stadsbadermarie.com	34, 82
Interpoint	www.interpoint-antwerpen.be	36, 37
Ignacio Carrasco y Alberto Porras	www.odonnell14.bulthaup.com	40, 41
Koeslag Dennis	info@studiofabels.nl	48, 58, 59
Inmaculada Recio, Silvia Trigueros	www.elerom62.com	51, 66, 67
Patricia Bustos	www.mrsblossom.es	64, 65
De Huiskamer	www.dehuiskamer.be	68, 69
Swyngedauw Nicolas	info@nsdeco.be	68, 69
Esfan Eghtessadi, Inge Onsea	www.essentiel-antwerp.com	70
Van Pamel Frederiek	www.frederiekvanpamel.be	71
Hotel Das Tegernsee	www.dastegernsee.de	72, 73
Pieter Porters	www.houseofporters.com	78, 79
Old School	www.oldschooltechniques.com	78, 79
Zariza Art	www.zarizart.ru	135
Maries Corner	www.mariescorner.com	143

Emilie, Anne Gaëlle, Grace, Astrid, Bettina, Antonio, Clément, Peter, Benedikt Vdv,
Verne, Brian Hallett, CASA DECOR Madrid

REGISTERED CTM DESIGN N°

C335/000995576-0001	C373/002524769-0005	CX176/003242569-0009	PX175/003242569-0012
C336/1035273-0001	C374/002524769-0006	CX177/003242569-0010	R70/2088880-0006
C337/1810706-0001	C380/003242569-0001	CX188/005329026-0004	SX156/000995576-0006
C338/1978214-0001	C381/003242569-0002	CX189/005329026-0005	SX165/002341727-0001
C338A/002341727-0007	C382/003242569-0003	CX190/005329026-0006	SX167/2088880-0007
C338B/002341727-0006	C383/003242569-0004	DX168-2300/002341727-0004	SX171/002920140-0001
C339/1978214-0002	C390/003242569-0005	DX170/002524769-0008	SX172/003242569-0013
C340/1978214-0003	C391/003242569-0006	DX174-2300/003242569-0011	SX173/003242569-0014
C341/002524769-0001	C392/003242569-0007	DX182/'004097780-0002	SX179/003242569-0015
C342/002524769-0002	C393/003242569-0008	DX183/'004097780-0003	SX180/003242569-0016
C343/002524769-0003	C394/005329026-0001	DX184/'004097780-0004	SX181/003242569-0017
C344/002524769-0004	C395/005329026-0002	G70/002158089-0001	SX185/'004097780-0005
C351/000257464-0003	C396/005329026-0003	G71/002158089-0002	SX186/'004097780-0006
C352/000257464-0004	C990/000995576-0002	G72/002158089-0003	SX187/005329026-0007
C353/000257464-0005	C991/002524769-0007	G73/002158089-0004	W100/003356278-0001
C354/000257464-0006	CB500/1035273-0006	P3020A/002341727-0005	W101/003356278-0002
C355/000257464-0007	CB501/1035273-0005	P3070/2088880-0004	W102/003356278-0003
C356/000257464-0008	CB502/1035273-0007	P3071/2088880-0005	W103/003356278-0004
C361/1890526-0001	CB503/1890526-0005	P8050/000995576-0003	W104/003356278-0005
C362/1890526-0002	CB510/1035273-0004	P8060/1810706-0002	W105/'004097780-0001
C363/1890526-0003	CB511/1035273-0003	P9900/000995576-0004	W106/005329026-0008
C364/1890526-0004	CB512/1890526-0007	P9901/000995576-0005	W107/005329026-0009
C370/2088880-0001	CB523/1035273-0002	PB513/1890526-0006	W108/005329026-0010
C371/2088880-0002	CB530/1890526-0008	PX147/002341727-0003	
C372/2088880-0003	CB531/1890526-0009	PX169/002341727-0002	

Guarantee terms and conditions apply if provided installation instructions have been followed to the letter. Fire retardant standards. In many interiors and projects strict fire regulations are imposed. Therefore, ORAC has implemented a number of solutions depending on the country and its regulations. Please contact us for more information.

The information in this catalogue is without engagement. Changes and discrepancies in sizes or/and shapes against those stated in the catalogue can occur.

This catalogue and the design embodied within are protected by copyright law and international treaties. Unauthorized reproduction of the catalogue, any portion of it or the reproduction of the designs embodied therein may result in severe civil and criminal penalties and will be prosecuted to the maximum.

Further legal information can be found on: www.oracdecor.com/nl/disclaimer.

ORAC HEADQUARTERS

NV ORAC SA
Biekorfstraat 32
8400 Ostend, BELGIUM
T +32 59 80 32 52
info@oracdecor.com

ORAC BELGIË

T +32 59 80 32 52
belgie@oracdecor.com
belgique@oracdecor.com

ORAC DEUTSCHLAND

T 0800 181 3694
deutschland@oracdecor.com

ORAC AUSTRIA

T 0800 292082
oesterreich@oracdecor.com

ORAC EXPORT

T +32 59 80 32 52
export@oracdecor.com

ORAC FRANCE

T 0800 900 358
france@oracdecor.com

ORAC NEDERLAND

T 0800 022 2125
nederland@oracdecor.com

ORAC RUSSIA

249020, Россия, Калужская область,
Боровский район, Индустриальный парк Ворсино,
3-ий восточный проезд, строение 4
ООО «Орак»
+7 495 799 70 60
info@oracdecor.ru

ORAC SLOVAKIA S.R.O.

Kpt. Nalepku 6
08271 Lipany - SK
T +421 514 891 581
slovakia@oracdecor.com

ORAC SPAIN

C/ Roger de Llúria 67-69 Pral 2^a
08009 Barcelona - Es
T 938 564 900
T 900 993 289
spain@oracdecor.com

ORAC (UK) LTD

City Business Centre
Brighton Road, Unit 8
Horsham RH13 5BB - UK
T +44 1403 240 102
uk@oracdecor.com